

Ted Steel

R.D.J Enterprises



**Manufacturers of Garment Racks
Sales and Rentals**

*Supplier To The Clothing Industry
With Over 36 Years Of Experience
In Retail Wholesale And Warehousing
Racks & Shelving*

We Can Custom Build To Your Needs

(212) 279-3878

(212) 244-1069

**361 W. 36th Street
New York, NY 10018**

www.allracks.net

All Racks Industries Inc. is the premier garment rack supplier in New York. Wholesale and consumer direct sales are available with nationwide shipping. Rentals are also available for your temporary needs. We have a wide selection of galvanized steel and chrome garment racks and hangers. We can easily accom-



modate those with special measurement requirements with custom sized racks.

All Racks Industries Inc. offers a full range of commercial and industrial shelving. We manufacture store fixtures

and display equipment fixtures for wholesale purchase. Let us give you a free approximated evaluation of your needs and your costs! With more than 35 years of experience and competitive prices, we are sure to get you organized.



(212) 279-3878

(212) 244-1069

361 W. 36th Street
New York, NY 10018

www.allracks.net

ROLLING RACKS

Chrome and Galvanized



**HEAVY WALL 1" PIPE
No. LR-1 ALL CHROME**

No. GLR-1 GALVANIZED

**HEAVY WALL 1 1/4" PIPE
No. LR-1 1/4 ALL CHROME**

No. GLR-1 1/4 GALVANIZED

**HEAVY WALL 1" PIPE
No. LR-4 ALL CHROME**

No. GLR-4 GALVANIZED

**HEAVY WALL 1 1/4" PIPE
No. LR-4 1/4 ALL CHROME**

No. GLR-4 1/4 GALVANIZED
Call for pricing on all items

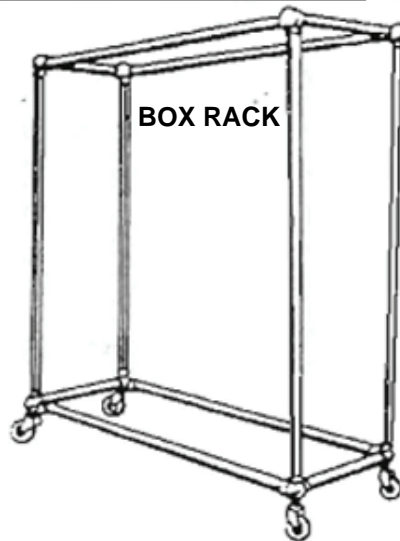

**HEAVY WALL 1" PIPE
No. LR-3 ALL CHROME**

No. GLR-3 GALVANIZED

**HEAVY WALL 1 1/4" PIPE
No. LR-3 1/4 ALL CHROME**

No. GLR-1 1/4 GALVANIZED
Call for pricing on all items



All Racks, Inc. led Steel, R.D.J. Enterprises

361 W. 36th Street
New York, NY 10018
www.allracks.net

(212) 279-3878

(212) 244-1069

RDJ ENTERPRISES

SPEED RAIL AND GARMENT RACKS
STEEL PARTITION AND SHELVING

361 W. 36th Street, New York, NY 10018

ALL RACKS
Tel: 212-244-1069

TED STEEL
Tel: 212-279-3878

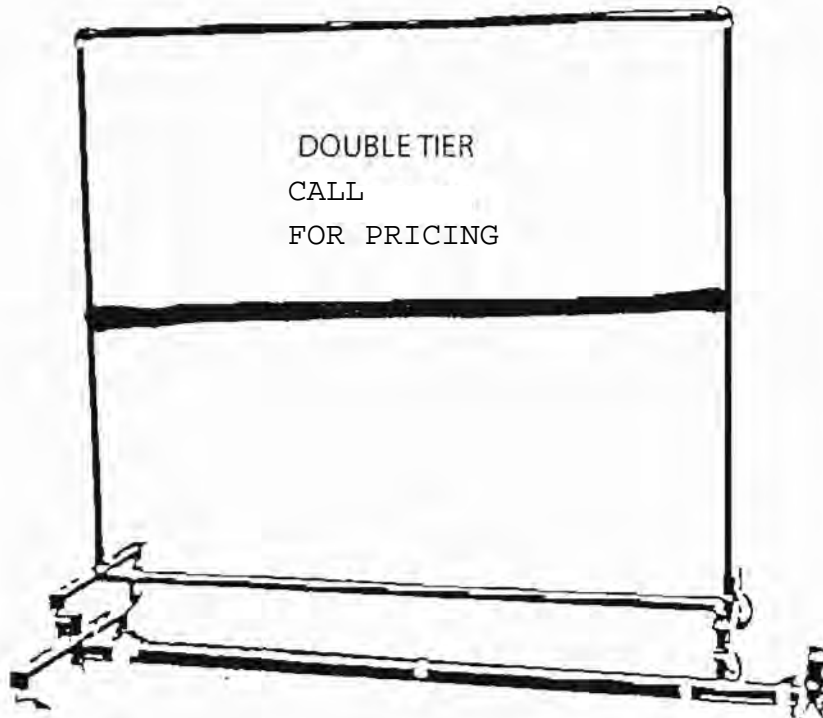
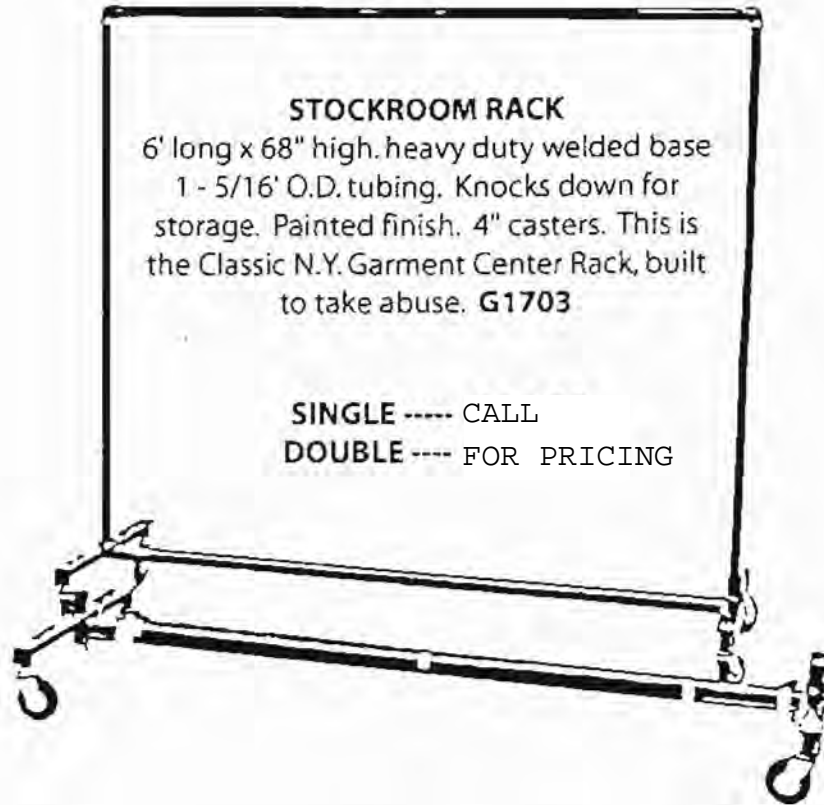

Item	Description	Color	Pack	Wt
------	-------------	-------	------	----

SLATWALL FACEOUT & WATERFALLS



SW/681	U-SHAPE ROUND TUBING HANGRAIL	CHROME	10	31.00
SWB/681	WITH CHROME STRIP	BLACK	10	31.00
SWW/681		WHITE	10	31.00



SW/R81	U-SHAPED RECTANGULAR TUBING HANGRAIL	CHROME	10	31.00
---------------	--------------------------------------	--------	----	-------

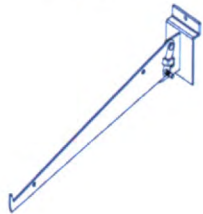

SW/ADJ12	12" ADJUSTABLE SHELF BRACKET	CHROME	25	33.00
SW/ADJ14	14" ADJUSTABLE SHELF BRACKET	CHROME	25	36.00



SW/FRC	3" FACEOUT W/ DISC AT END	CHROME	25	8.00
---------------	---------------------------	--------	----	------

WIRE SHELF & CAP DISPLAYER



SP2412	24"X12" SHELF	CHROME	6	27.00
SPB2412		BLACK	6	27.00
SPW2412		WHITE	6	27.00

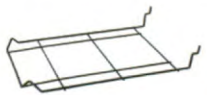



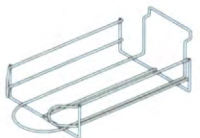

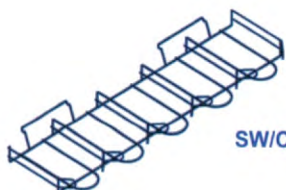

SP/CAP	1/8" WIRE CAP DISPLAYER	CHROME	25	18.00
SPB/CAP		BLACK	25	18.00
SPW/CAP		WHITE	25	18.00

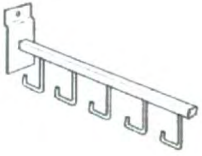

SP/CAP-S	WIRE CAP DISPLAYER	CHROME	20	15.00
SPB/CAP-S	HOLDS 12 CAPS	BLACK	20	15.00
SPW/CAP-S		WHITE	20	15.00

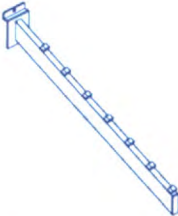

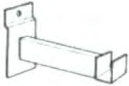
SW/CAP5	CAP HOLDER for SLATWALL 44"(W) X 12"(D) HOLDS 60 CAPS	BLACK	1	8.00
----------------	---	-------	---	------

Item	Description	Color	Pack	Wt	
SLATWALL FACEOUT & WATERFALLS					
	SW/12 SWB/12 SWW/12	12" FACEOUT - SQUARE TUBING	CHROME BLACK WHITE	25 25 25	20.00 20.00 20.00
	SW/5H SWB/5H SWW/5H	5-HOOK WATERFALL - SQUARE TUBING	CHROME BLACK WHITE	25 25 25	29.00 29.00 29.00
	SW/6B SWB/6B SWW/6B	6-BALL WATERFALL - SQUARE TUBING	CHROME BLACK WHITE	25 25 25	28.00 28.00 28.00
	RW/12	12" FACEOUT - RECTANGULAR TUBING	CHROME	25	24.00
	RW/3	3" FACEOUT - RECTANGULAR TUBING	CHROME	25	9.00
	RW/6	6" FACEOUT - RECTANGULAR TUBING	CHROME	25	11.00
	RW/5H	5-HOOK WATERFALL - RECTANGULAR TUBING	CHROME	25	33.00
	RW7B	7-CUBE WATERFALL - RECTANGULAR TUBING	CHROME	25	30.00
	SW/FB	12" RECT. HANGRAIL BRACKET FOR RE TUBUNG	CHROME	25	32.00
	SW/R2	2" RECT. HANGRAIL BRACKET FOR RE TUBING	CHROME	25	17.00
	SW/RM	12" HANGRAIL B/K FOR 1"X1-1/16" ROUND HANGRAIL	CHROME	25	30.00
	SW/RT	12" HANGRAIL B/K FOR 1-1/4" ROUND HANGRAIL	CHROME	25	30.00
	SW/ML SWB/ML SWW/ML	MILLINERY DISPLAYER	CHROME BLACK WHITE	25 25 25	15.00 15.00 15.00

Item	Description	Color	Pack	Wt
------	-------------	-------	------	----

SPECIAL SLATWALL HOOKS & PEG HOOKS

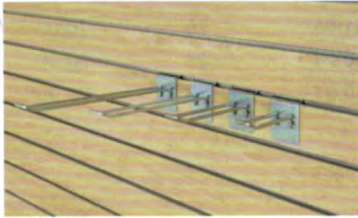

SW/UH4		ZINC	100	28.00
SW/UH6			100	30.00
SW/UH8			100	33.00
SW/UH10			100	37.00
3/16" wire				

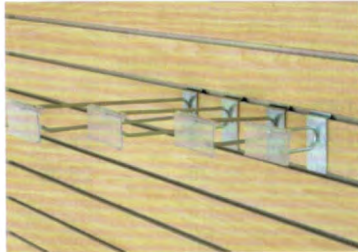

SW/SNH4		ZINC	100	16.00
SW/SNH6			100	22.00
SW/SNH8			100	26.00
SW/SNH10			100	27.00
3/16" wire with PLASTIC LABEL HOLDER				



PEG/BH4		ZINC	100	4.00
PEG/BH6			100	6.00
PEG/BH8			100	7.00
PEG/BH10			100	10.00
3/16" wire BALL TIP END				

SLATWALL BRACKETS

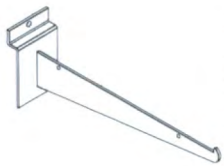

SW/8KB	8" KNIFE BRACKET	CHROME	50	21.00
SWB/8KB		BLACK	50	21.00
SWW/8KB		WHITE	50	21.00
SW/10KB	10" KNIFE BRACKET	CHROME	50	23.00
SWB/10KB		BLACK	50	23.00
SWW/10KB		WHITE	50	23.00
SW/12KB	12" KNIFE BRACKET	CHROME	50	26.00
SWB/12KB		BLACK	50	26.00
SWW/12KB		WHITE	50	26.00
SW/14KB	14" KNIFE BRACKET	CHROME	50	29.00
SWB/14KB		BLACK	50	29.00
SWW/14KB		WHITE	50	29.00
SW/16KB	16" KNIFE BRACKET	CHROME	50	35.00
SWB/16KB		BLACK	50	35.00
SWW/16KB		WHITE	50	35.00

Item	Description	Color	Pack	Wt
------	-------------	-------	------	----

SLATWALL HOOKS



SW/NHK	NOTCH HOOK	CHROME	100	10.00
SWB/NHK		BLACK	100	10.00
SWW/NHK		WHITE	100	10.00
SW/H1	1" HOOK	CHROME	100	12.00
SWB/H1		BLACK	100	12.00
SWW/H1		WHITE	100	12.00
SW/H2	2" HOOK	CHROME	100	14.00
SWB/H2		BLACK	100	14.00
SWW/H2		WHITE	100	14.00
SW/H4	4" HOOK	CHROME	100	14.00
SWB/H4		BLACK	100	14.00
SWW/H4		WHITE	100	14.00
SW/H6	6" HOOK	CHROME	100	17.00
SWB/H6		BLACK	100	17.00
SWW/H6		WHITE	100	17.00
SW/H8	8" HOOK	CHROME	100	20.00
SWB/H8		BLACK	100	20.00
SWW/H8		WHITE	100	20.00
SW/H10	10" HOOK	CHROME	100	23.00
SWB/H10		BLACK	100	23.00
SWW/H10		WHITE	100	23.00
SW/H12	12" HOOK	CHROME	100	28.00
SWB/H12		BLACK	100	28.00
SWW/H12		WHITE	100	28.00



SLATWALL HOOKS - SATIN CHROME



SW/H6-SC	6" HOOK - SATIN CHROME	SATIN CHROME	100	17.00
SW/H8-SC	8" HOOK - SATIN CHROME	SATIN CHROME	100	20.00
SW/H10-SC	10" HOOK -SATIN CHROME	SATIN CHROME	100	23.00

SLATWALL THIN HOOKS



XTW/H1	1" THIN HOOK	CHROME	100	13.00
XTW/H4	4" THIN HOOK	CHROME	100	13.00
XTW/H6	6" THIN HOOK	CHROME	100	15.00
XTW/H8	8" THIN HOOK	CHROME	100	17.00
XTW/H10	10" THIN HOOK	CHROME	100	19.00
XTW/H12	12" THIN HOOK	CHROME	100	21.00

Item - Description
PLASTIC INJECTION MOLDED SHELVING

Color

Pack

Wt

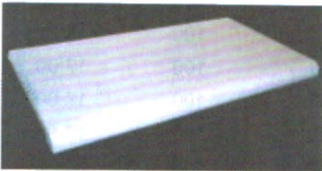
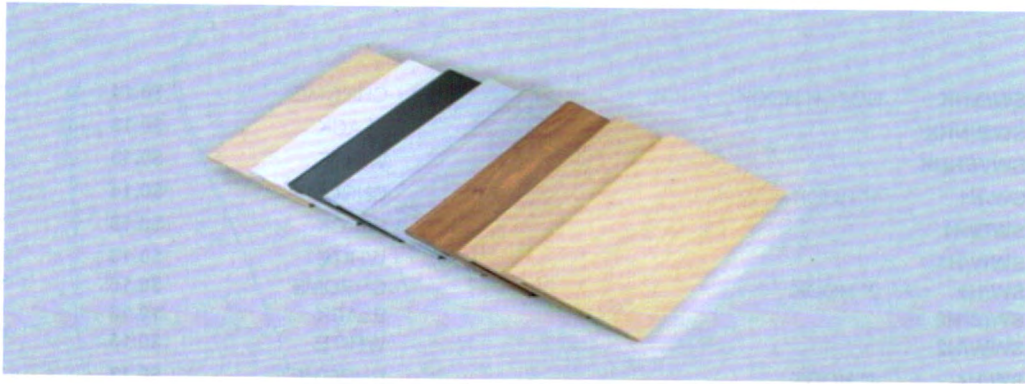

WHITE INJECTION MOLDED SHELF

IMS2413/W (24"W x 13"D)
 IMS4813/W (48"W x 13"D)

WHITE
 WHITE

4
 4

10.00
 19.00



BLACK INJECTION MOLDED SHELF

IMS2413/B (24"W x 13"D)
 IMS4813/B (48"W x 13"D)

BLACK
 BLACK

4
 4

10.00
 19.00

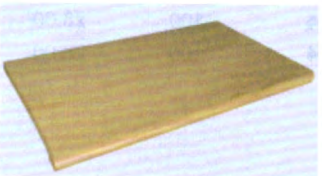

MAPLE INJECTION MOLDED SHELF

IMS2413/M (24"W x 13"D)
 IMS4813/M (48"W x 13"D)

MAPLE
 MAPLE

4
 4

10.00
 19.00



CHERRY INJECTION MOLDED SHELF

IMS2413/C (24"W x 13"D)
 IMS4813/C (48"W x 13"D)

CHERRY
 CHERRY

4
 4

10.00
 19.00

MELAMINE WOOD SHELVING - 3/4" THICKNESS



WS1224-WHITE
 WS1248-WHITE
 WS1448-WHITE

12" X 24"
 12" X 48"
 14" X 48"

8
 4
 4

47.00
 47.00
 54.00



WS1224-BLACK
 WS1248-BLACK
 WS1448-BLACK

12" X 24"
 12" X 48"
 14" X 48"

8
 4
 4

47.00
 47.00
 54.00

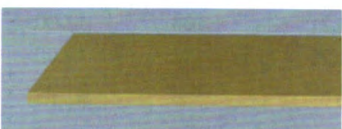

WS1224-MAPLE
 WS1248-MAPLE
 WS1448-MAPLE

12" X 24"
 12" X 48"
 14" X 48"

8
 4
 4

47.00
 47.00
 54.00

Item	Description	Color	Pack	Wt
------	-------------	-------	------	----

WOOD BASE for GLASS DISPLAY

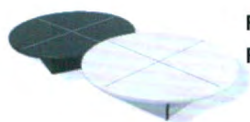

RRB-B	ROUND BASE - 30" DIAMETER BASE	BLACK	1	33.00
RRB-W		WHITE	1	33.00

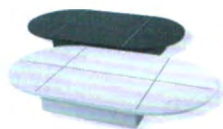

OB-B	OVAL BASE	BLACK	1	46.00
OB-W	- 54"L x 30"W x 6"H - W/ GROOVE	WHITE	1	46.00



RB50-B	RECTANGULAR BASE - 50"L x 12"W x 9"H	BLACK	1	40.00
RB50-W		WHITE	1	40.00
RB58-B	RECTANGULAR BASE - 58"L x 14"W x 9"H	BLACK	1	48.00
RB58-W		WHITE	1	48.00

GLASS CONNECTORS(CHROME)



CON-2	2-WAY CONNECTOR	CHROME	100	20.00
CON-3	3-WAY CONNECTOR	CHROME	100	23.00
CON-4	4-WAY CONNECTOR	CHROME	100	29.00

TEMPERED 3/16" GLASS SHELVES



GS1024	(10" x 24" TEMPERED 3/16" GLASS SHELF)	GLASS	10	45.00
GS1224	(12" x 24" TEMPERED 3/16" GLASS SHELF)	GLASS	10	53.00
GS1424	(14" x 24" TEMPERED 3/16" GLASS SHELF)	GLASS	5	33.00
GS1036	(10" x 36" TEMPERED 3/16" GLASS SHELF)	GLASS	5	31.00
GS1236	(12" x 36" TEMPERED 3/16" GLASS SHELF)	GLASS	5	37.00
GS1436	(14" x 36" TEMPERED 3/16" GLASS SHELF)	GLASS	5	42.00
GS1048	(10" x 48" TEMPERED 3/16" GLASS SHELF)	GLASS	5	45.00
GS1248	(12" x 48" TEMPERED 3/16" GLASS SHELF)	GLASS	5	53.00
GS1448	(14" x 48" TEMPERED 3/16" GLASS SHELF)	GLASS	5	73.00



GS1212	(12" x 12" x 3/16"(T) TEMPERED GLASS)	GLASS	10	24.00
GS1414	(14" x 14" x 3/16"(T) TEMPERED GLASS)	GLASS	10	33.00



QRG12	(12" QUARTER ROUND TEMPERED GLASS)	GLASS	10	18.00
QRG14	(14" QUARTER ROUND TEMPERED GLASS)	GLASS	10	26.00

Item	Description	Color	Pack	Wt
------	-------------	-------	------	----

EXTRA VISION SHOWCASE

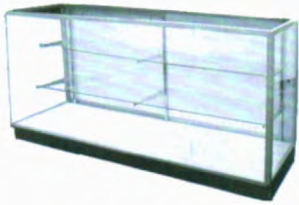

K/D EXTRA VISION SHOWCASE

ESC4	4' EXTRA VISION SHOWCASE		1	195.00
ESC6	6' EXTRA VISION SHOWCASE		1	255.00



EMD - 4	MIRROR DOOR FOR EXTRA VISION 4' SHOWCASE		1	16.00
EMD - 6	MIRROR DOOR FOR EXTRA VISION 6' SHOWCASE		1	20.00



EPC	CORNER FILLER		1	45.00
------------	---------------	--	---	-------



EX-BCC	CORNER CASE - 42" SQUARE, 20"D, 38"H , 60"DIAGONAL		1	195.00
---------------	---	--	---	--------



WALL CASE

WC4	48"(L) X 18" (W) X 78"(H) 5-ADJUSTABLE GLASS SHELVES (12") 3 - HOLOGEN LIGHTS PLUNGER	MAPLE	1	304.00
------------	--	-------	---	--------



WRAP COUNTER

CW4(W)	38"(H) x 18"(D) x 48"(W)	WHITE	1	139.00
CW4(M)		MAPLE	1	139.00
CW6(W)	38"(H) x 18"(D) x 72"(W)	WHITE	1	190.00
CW6(M)		MAPLE	1	190.00

Item	Description	Color	Pack	Wt
	CASH REGISTER STANDS INCLUDE			
	1-WOOD SHELF			
	4" HIGH DRAWER			
	24"(L) x 18"(W) X 38"(H)			
SCRCB	CASH REGISTER STAND	BLACK	1	81.00
SCRCW		WHITE	1	81.00
SCRCM		MAPLE	1	81.00
SCRCC		CHERRY	1	81.00



	CASH REGISTER STAND W/ GLASS FRONT INCLUDE			
	1-GLASS SHELF			
	24"(L) x 18"(W) X 38"(H)			
	SCRGB	CASH REGISTER STAND WITH GLASS	BLACK	1
SCRGW		WHITE	1	68.00
SCRGM		MAPLE	1	68.00
SCRGC		CHERRY	1	68.00



	TRIANGLE CORNERS INCLUDE			
	2 - GLASS SHELVES			
	18"(L) X 18" (W) X 38"(H)			
	SCTCB	TRIANGLE CORNER WITH GLASS SHELF	BLACK	1
SCTCW		WHITE	1	36.00
SCTCM		MAPLE	1	36.00
SCTCC		CHERRY	1	36.00



	PENTAGONAL CORNERS INCLUDE			
	2-GLASS SHELVES			
	18"(L) X 18" (W) X 38"(H)			
	SCPC18B	PENTAGONAL CORNER WITH GLASS SHELF	BLACK	1
SCPC18W		WHITE	1	38.00
SCPC18M		MAPLE	1	38.00
SCPC18C		CHERRY	1	38.00



SC-PL	PLUNGER LOCK		1	
SC-RL	RACHET LOCK		1	



LIGHT4	4' SHOWCASE LIGHTING		1	
LIGHT5	5' SHOWCASE LIGHTING		1	
LIGHT6	6' SHOWCASE LIGHTING		1	

Item	Description	Color	Pack	Wt
------	-------------	-------	------	----

FULL VISION SHOWCASE

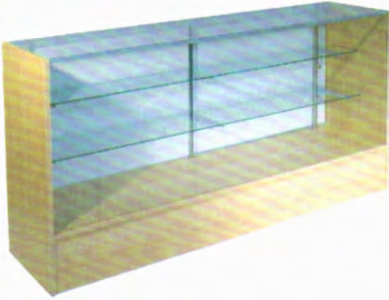

SHOWCASES INCLUDE
 2-GLASS SHELVES (10" and 12")
 SHELF BRACKETS
 4' SHOWCASE DIMENSION - 48" X 18" X 38"
 5' SHOWCASE DIMENSION - 60" X 18" X 38"
 6' SHOWCASE DIMENSION - 72" X 18" X 38"



FMD - 4
 MIRROR DOOR FOR FULL
 VISION 4' SHOWCASE
 Pack:1 Wt:16.00

FMD - 6
 MIRROR DOOR FOR FULL
 VISION 6' SHOWCASE
 Pack:1 Wt:20.00

SC4B	4' FULL VISION SHOW CASE	BLACK	1	130.00
SC5B	5' FULL VISION SHOW CASE	BLACK	1	158.00
SC6B	6' FULL VISION SHOW CASE	BLACK	1	180.00
SC4W	4' FULL VISION SHOW CASE	WHITE	1	130.00
SC6W	6' FULL VISION SHOW CASE	WHITE	1	180.00
SC4M	4' FULL VISION SHOW CASE	MAPLE	1	130.00
SC5M	5' FULL VISION SHOW CASE	MAPLE	1	158.00
SC6M	6' FULL VISION SHOW CASE	MAPLE	1	180.00
SC4C	4' FULL VISION SHOW CASE	CHERRY	1	130.00
SC5C	5' FULL VISION SHOW CASE	CHERRY	1	158.00
SC6C	6' FULL VISION SHOW CASE	CHERRY	1	180.00

HALF VISION SHOWCASE

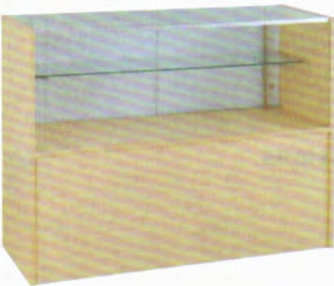

SHOWCASES INCLUDE
 1-GLASS SHELF (12")
 SHELF BRACKETS
 4' SHOWCASE DIMENSION - 48" X 18" X 38"
 6' SHOWCASE DIMENSION - 72" X 18" X 38"

SCH4B	4' HALF VISION SHOW CASE	BLACK	1	133.00
SCH6B	6' HALF VISION SHOW CASE	BLACK	1	216.00
SCH4W	4' HALF VISION SHOW CASE	WHITE	1	133.00
SCH6W	6' HALF VISION SHOW CASE	WHITE	1	216.00
SCH4M	4' HALF VISION SHOW CASE	MAPLE	1	133.00
SCH6M	6' HALF VISION SHOW CASE	MAPLE	1	216.00

Item	Description	Color	Pack	Wt
MINIATURE JEWELRY RACK				
	MR10 FRAME HEIGHT : 4 5/8" Adjustable Arm	CHROME	1	2.00
	MR20 FRAME HEIGHT : 4 3/4" Adjustable Arm	CHROME	1	2.00
	MR58 FRAME HEIGHT : 5 7/8" 16 Hooks	CHROME	1	2.00
	MR53 FRAME HEIGHT : 4 1/2" Adjustable Ring	CHROME	1	2.00
	MRBB FRAME HEIGHT : 4 3/4" Adjustable Arm	CHROME	1	2.00

ANTIQUE JEWELRY DISPLAYS



FA-004
8"Wx10"H



FA-003
6 1/2"Wx10"H



FA-036
11 1/2"Wx10 1/2"H



FA-020
12 1/2"Wx13"H



FA-066
9 1/2"Wx13 1/2"H



FA-148
12"Wx11 1/2"H



FA-030
12"Wx12"H



FA-290
10"Wx10 1/2"H

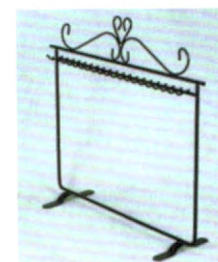

FA-058
12 1/2"Wx11 1/2"H



FA-269
12 1/2"Wx11 1/2"H



FA-270
8"Wx9 1/2"H

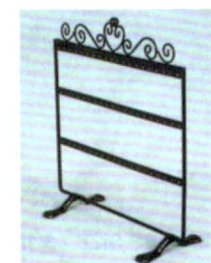

FA-268
10"Wx10 1/2"H

Item	Description	Color	Pack	Wt
	2 WAY SPINNING JEWELRY TOWER SJT-2 3" HOOKS SOLD SEPARATELY BASE - 11 1/2" x 4 1/2" 15 1/2"(H) x 11 1/2"(W)	CHROME	1	11.00
	4 WAY SPINNING JEWELRY TOWER SJT-4 3" HOOKS SOLD SEPARATELY BASE - 12" x 12" 18 1/2"(H) x 12"(W) x 12"(W)	CHROME	1	18.00
	3" HOOK	CHROME	12	1.00

METAL SHOE DISPLAY



CSR-SS	ADJUSTABLE SHOE RISER BASE SIZE - 6" x 4" ADJUSTABLE FROM 14" TO 22"	CHROME	1	3.00
---------------	--	--------	---	------



CSR-8	Height : 8", BASE SIZE - 3 1/2" x 7"	CHROME	1	3.00
CSR-10	Height : 10", BASE SIZE - 3 1/2" x 7"	CHROME	1	3.00
CSR-12	Height : 12", BASE SIZE - 3 1/2" x 7"	CHROME	1	3.00

METAL COUNTERTOP DISPLAYS

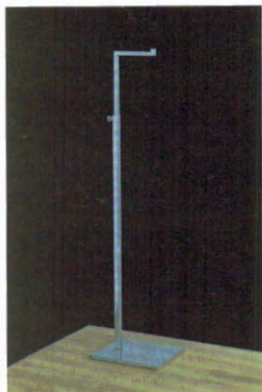
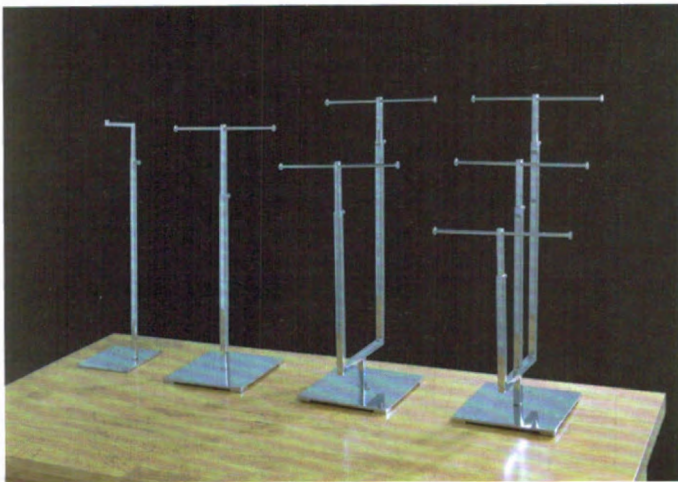

ITEM : CSR-L

L-JEWELRY STAND - CHROME
5" SQ. BASE
ADJUSTABLE UPRIGHT FROM 17" TO 31"

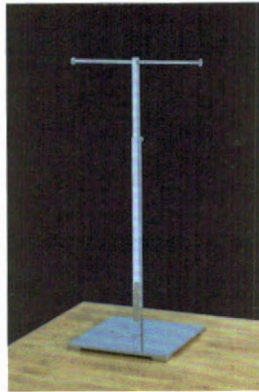

ITEM : CSR-1

SINGLE JEWELRY STAND - CHROME
7" SQ. BASE
ADJUSTABLE UPRIGHT FROM 14" TO 24"



ITEM : CSR-2

2-TIER JEWELRY STAND - CHROME
7" SQ. BASE
ADJUSTABLE UPRIGHT FROM 15" TO 25"
& 18" TO 29"

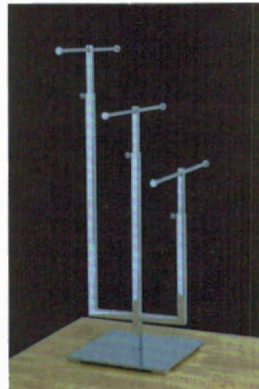

ITEM : CSR-3

3-TIER JEWELRY STAND - CHROME
7" SQ. BASE
ADJUSTABLE UPRIGHT FROM 11" TO 18"
& 15" TO 25" & 18" TO 29"



ITEM : CSR-EF

INCLUDING 40 PIECES of 3" HOOKS - CHROME
15"(W) x 5.5"(D) x 18.25" (H)



ITEM : CSR-SBS

SINGLE BRACELET STAND - CHROME
13.25(W) x 4"(D) x 8.2" (H)

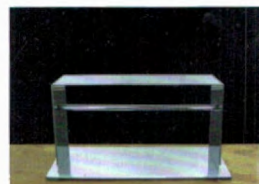

ITEM : CSR-DBS

DOUBLE BRACELET STAND - CHROME
13.25(W) x 4"(D) x 11.25" (H)

Item	Description	Color	Pack	Wt
------	-------------	-------	------	----

COUNTER TOP SIGN HOLDERS



SHPK57 7"(W) X 5-1/2"(H) CLEAR SIGN HOLDER with METAL BASE



CLEAR & CHROME

24 29.00



SHPK711 11"(W) X 7"(H) CLEAR SIGN HOLDER with METAL BASE



CLEAR & CHROME

24 41.00

STEM MOUNT SIGN-HOLDER



MC57 7"W X 5-1/2"H SIGN HOLDER W/ 1/4" X 3/8" FITTING
MC711 11"W X 7-1/2"H SIGN HOLDER W/ 1/4" X 3/8" FITTING



CHROME
 CHROME

25 9.00
 25 14.00



PJ57 7"W X 5-1/2"H CLEAR SIGN HOLDER W/ 3/8" FITTING
PJ711 11"W X 7-1/2"H CLEAR SIGN HOLDER W/ 3/8" FITTING
PJ811 11"W X 8-1/2"H CLEAR SIGN HOLDER W/ 3/8" FITTING

CHROME
 CHROME
 CHROME

25 10.00
 25 19.00
 25 21.00



SC22 ALL PURPOSE CLAMPS

CHROME

100 13.00



M3 3/8" X 3" THREADED STEM
M6 3/8" X 6" THREADED STEM

CHROME
 CHROME

100 10.00
 100 20.00



NS3 3/8" X 3" SWEDGED STEM
NS6 3/8" X 6" SWEDGED STEM

CHROME
 CHROME

100 10.00
 100 20.00



MAG/S 90 DEGREE MAGNETIC CLAMP FITS 3/8" SWEDGE STEM
MAG/T 90 DEGREE MAGNETIC CLAMP FITS 3/8" THREADED STEM

CHROME
 CHROME

100 22.00
 100 22.00



MAG/LS 4" WIDE MAGNETIC BASE FITS 3/8" SWEDGE STEM
MAG/LT 4" WIDE MAGNETIC BASE FITS 3/8" THREADED STEM

CHROME
 CHROME

100 29.00
 100 29.00

Item	Description	Color	Pack	Wt
------	-------------	-------	------	----

3/4 TORSO BODY FORM



ITEM : BFF-3/4/C-M
 PRICE : \$63.00



FEMALE 3/4 TORSO BODY FORM
 W/METAL FLAT BASE



ITEM : BFM-3/4/C-I
 PRICE : \$63.00



MALE 3/4 TORSO BODY FORM
 W/METAL FLAT BASE

DRESS MAKER FORM



DMF-6 COLLAPSIBLE SHOULDERS - SIZE 6

DMF-8 COLLAPSIBLE SHOULDERS - SIZE 8



1 34.00

1 34.00

BODY FORM BASE



FMB/4 FLOOR STAND

CLEAR COAT

1 16.00



SQB/1 SQUARE WEIGHTED BASE WITH 1" DIA UPRIGHT

SATIN CHR.

1 16.00



DMB/1 DRESSMAKER BASE WITH 7/8" UPRIGHT

CHROME

1 33.00

MINI LADDER

ML55/MAB 55" MINI LADDER - MATTE BLACK

MT BLK

1 24.00

ML73/MAB 73" MINI LADDER - MATTE BLACK

MT BLK

1 32.00



Item	Description	Color	Pack	Wt	
FORMS W/ METAL AND WOOD BASE					
	BFF/C-M	FEMALE 3/4 BODY FORM W/METAL FLAT BASE			
	BFF/B-M	METAL FLAT BASE FINISH - SATIN CHROME	OFF WHITE	2	40.00
		METAL FLAT BASE FINISH - SATIN CHROME	BLACK	2	40.00
	BFF/C-W	FEMALE 3/4 BODY FORM W/WOOD TRIPOD BASE			
	BFF/B-W	WOOD TRIPOD BASE FINISH - NATURAL	OFF WHITE	2	40.00
		WOOD TRIPOD BASE FINISH - BLACK	BLACK	2	40.00
	BFM/C-M	MALE 3/4 BODY FORM W/METAL FLAT BASE			
	BFM/B-M	METAL FLAT BASE FINISH - SATIN CHROME	OFF WHITE	2	40.00
		METAL FLAT BASE FINISH - SATIN CHROME	BLACK	2	40.00
	BFM/C-W	MALE 3/4 BODY FORM W/WOOD TRIPOD BASE			
	BFM/B-W	WOOD TRIPOD BASE FINISH - NATURAL	OFF WHITE	2	40.00
		WOOD TRIPOD BASE FINISH - BLACK	BLACK	2	40.00

**AVAILABLE IN BLACK OR WHITE
GLOSS LACQUER FINISH**

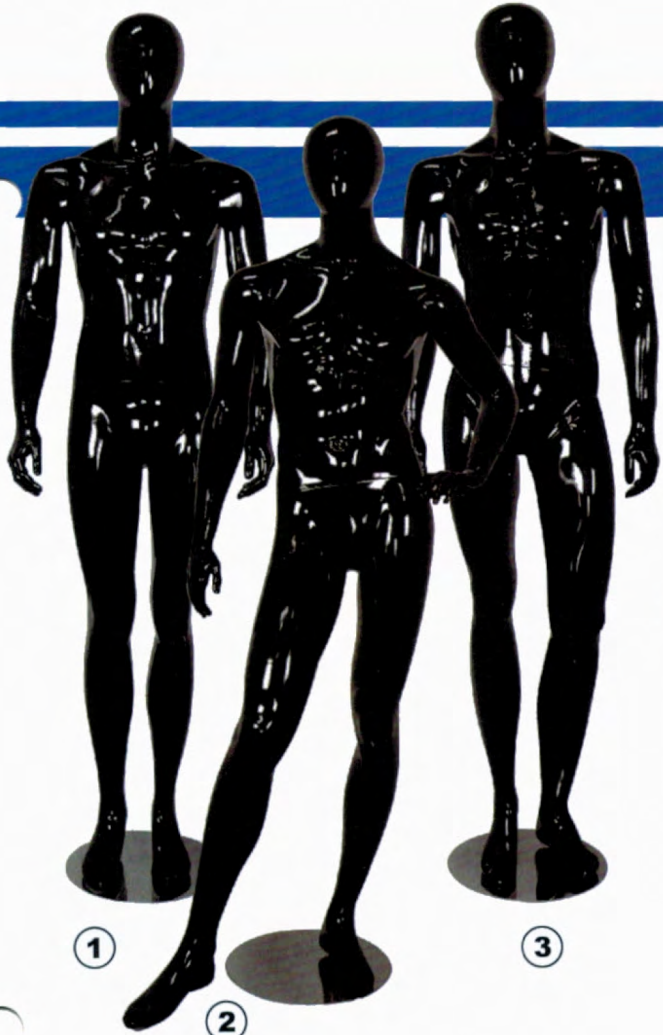

**1 MIKE/1(BLACK)
MIKE/1(WHITE)**
Shoulder:20 7/8"
Waist:31"
Hip:37 3/4"
Height:6'2 7/8"
GLOSSY BLACK
GLOSSY WHITE

**2 MIKE/2(BLACK)
MIKE/2(WHITE)**
Shoulder:20 7/8"
Waist:31"
Hip:37 3/4"
Height:6'2 7/8"
GLOSSY BLACK
GLOSSY WHITE

**3 MIKE/3(BLACK)
MIKE/3(WHITE)**
Shoulder:20"
Waist:30 3/4"
Hip:37 3/4"
Height:6'2 7/8"
GLOSSY BLACK
GLOSSY WHITE

**1 MICHELLE/1(WHITE)
MICHELLE/1(BLACK)**
Shoulder:15 3/4"
Chest:32 1/2"
Waist:23 1/2"
Hip:34 1/4"
Height:5' 9 5/8"
GLOSSY WHITE
GLOSSY BLACK

**2 MICHELLE/2(WHITE)
MICHELLE/2(BLACK)**
Shoulder:15 3/4"
Chest:32 1/2"
Waist:23 1/2"
Hip:34 1/4"
Height:5' 9 5/8"
GLOSSY WHITE
GLOSSY BLACK

**3 MICHELLE/3(WHITE)
MICHELLE/3(BLACK)**
Shoulder:17 1/2"
Chest:32 1/2"
Waist:24"
Hip:34"
Height:5' 9 5/8"
GLOSSY WHITE
GLOSSY BLACK

**4 MICHELLE/4(WHITE)
MICHELLE/4(BLACK)**
Shoulder:16"
Chest:33"
Waist:25 1/4"
Hip:36 1/4"
Height:5' 9 5/8"
GLOSSY WHITE
GLOSSY BLACK

**5 MICHELLE/5(WHITE)
MICHELLE/5(BLACK)**
Shoulder:16"
Chest:33"
Waist:25 1/4"
Hip:36 1/4"
Height:3' 9 5/8"
GLOSSY WHITE
GLOSSY BLACK

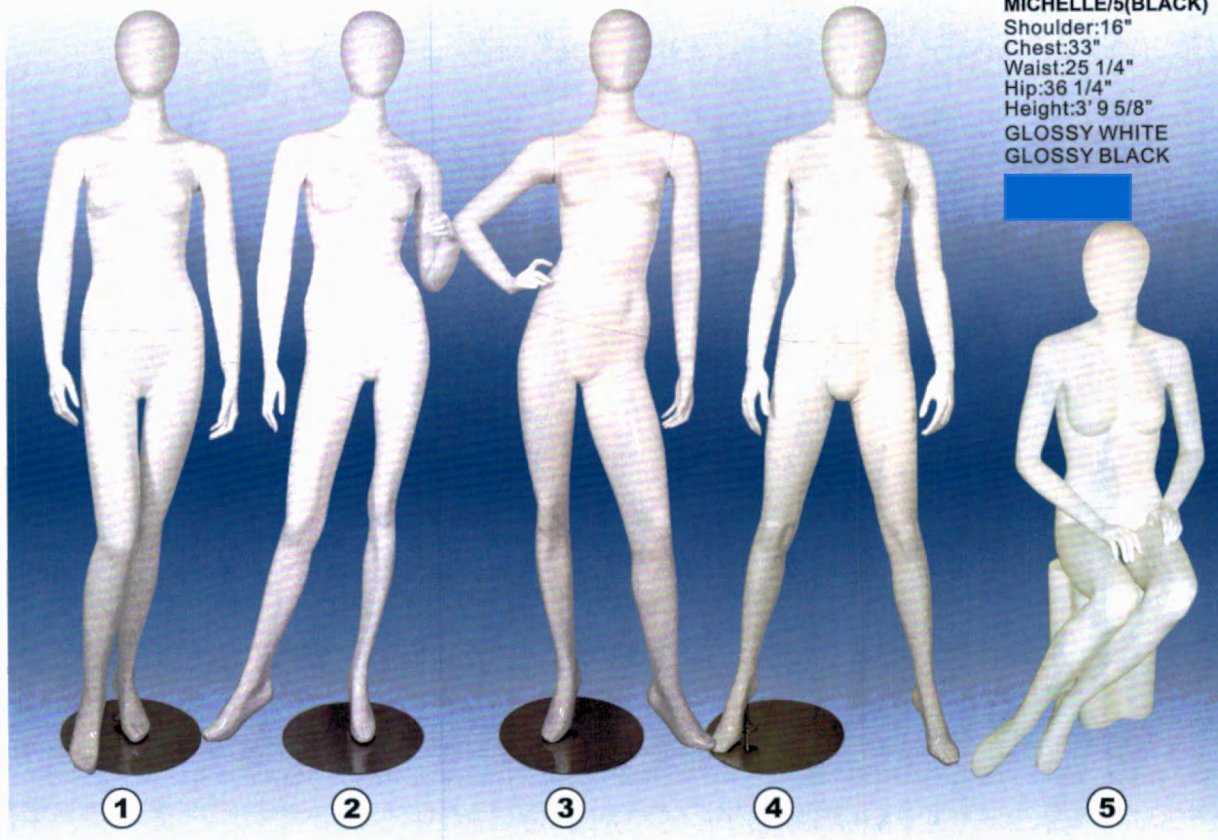

Mannequin

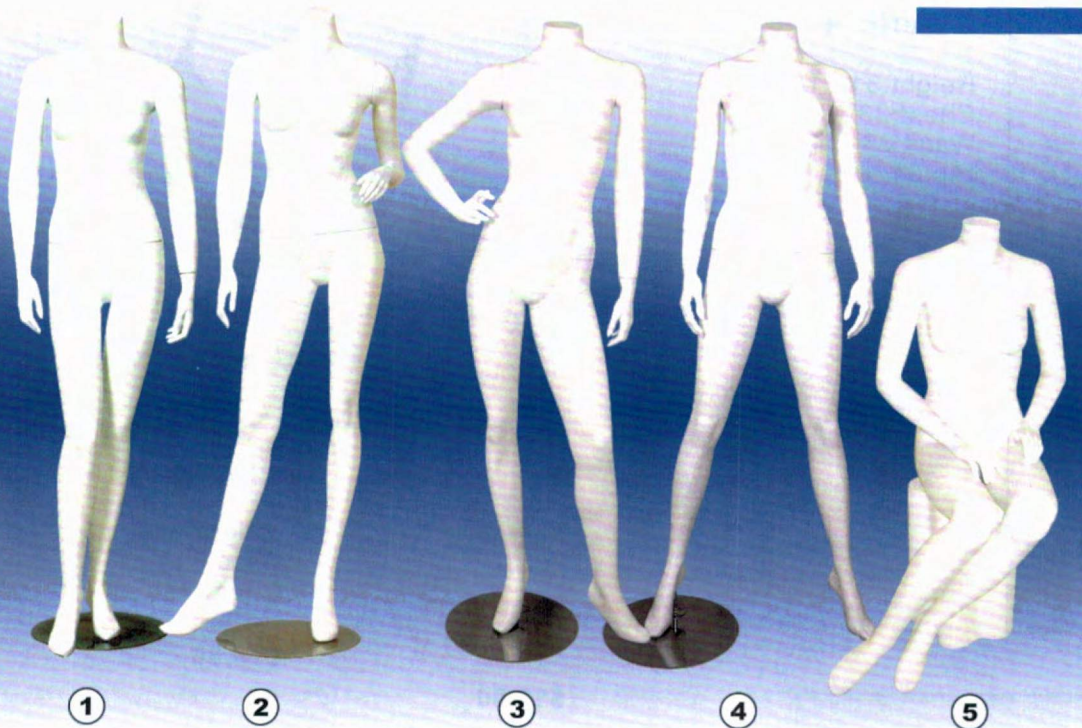

① ERICA/1
 Shoulder:15 3/4"
 Chest:32 1/2"
 Waist:23 1/2"
 Hip:34 1/4"
 Height:5' 2"
 WHITE

② ERICA/2
 Shoulder:15 3/4"
 Chest:32 1/2"
 Waist:23 1/2"
 Hip:34 1/4"
 Height:5' 2"
 WHITE

③ ERICA/3
 Shoulder:17 3/4"
 Chest:32 1/2"
 Waist:24"
 Hip:34"
 Height:5' 2"
 WHITE

④ ERICA/4
 Shoulder:16"
 Chest:33"
 Waist:25 1/4"
 Hip:36 1/4"
 Height:5' 2"
 WHITE

⑤ ERICA/5
 Shoulder:16"
 Chest:33"
 Waist:25 1/4"
 Hip:36 1/4"
 Height:3' 2"
 WHITE

① ERIC/1
 Shoulder:20 7/8"
 Waist:31"
 Hip:37 3/4"
 Height:5' 8"
 WHITE

② ERIC/2
 Shoulder:20 7/8"
 Waist:31"
 Hip:37 3/4"
 Height:5' 8"
 WHITE

③ ERIC/3
 Shoulder:20"
 Waist:30 3/4"
 Hip:37 3/4"
 Height:5' 4 1/8"
 WHITE

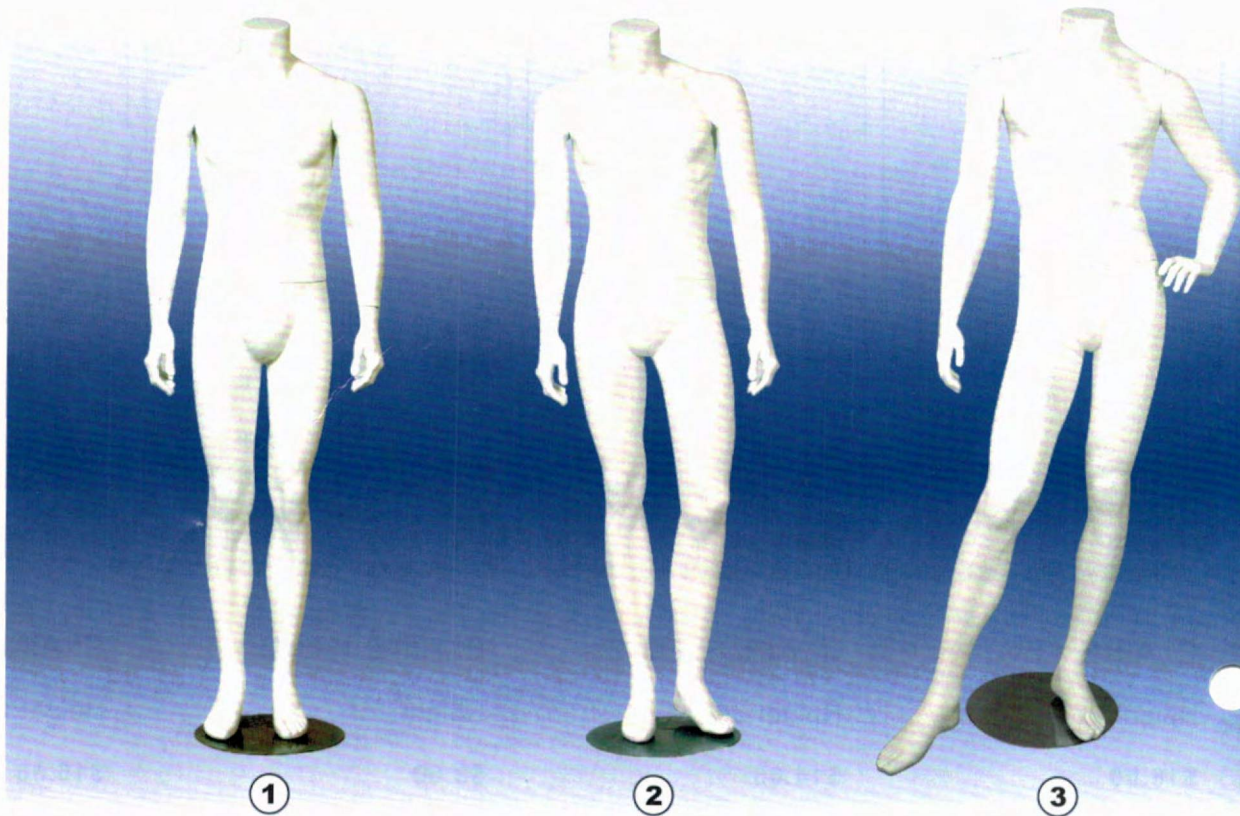

①

②

③

Item	Description	Color	Pack	Wt
------	-------------	-------	------	----

PLASTIC HANGERS

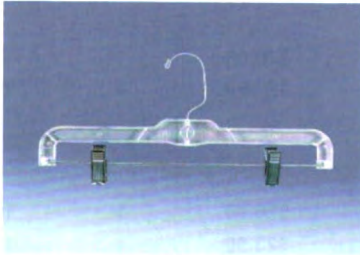

SH14C - 14" CRYSTAL CLEAR SKIRT & SLACK HANGER WITH METAL CLIPS AND SWIVEL HOOK(HEAVY WEIGHT)

PACKING: 100/CTN
WEIGHT: 18.5 LBS

SH14B - 14" BLACK SKIRT & SLACK HANGER WITH BLACK PLASTIC CLIPS AND BLACK SWIVEL HOOK(HEAVY WEIGHT)

PACKING: 100/CTN
WEIGHT: 18.5 LBS

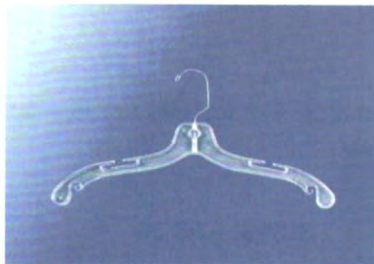
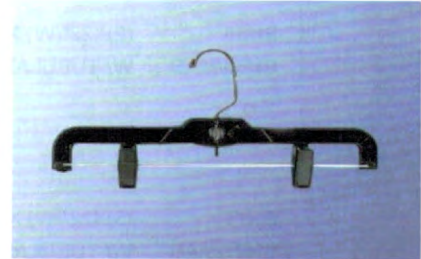

SH17C - 17" CRYSTAL CLEAR DRESS & SHIRT HANGERS WITH SWIVEL HOOK(HEAVY WEIGHT)

PACKING: 100/CTN
WEIGHT: 15.4 LBS

SH17C-M - 17" CRYSTAL CLEAR DRESS & SHIRT HANGERS WITH SWIVEL HOOK (HEAVY WEIGHT)
PACKING: 100/CTN

SH17B - 17" BLACK DRESS & SHIRT HANGERS WITH SWIVEL HOOK(HEAVY WEIGHT)

PACKING: 100/CTN
WEIGHT: 15.4 LBS

SH17B-M - 17" BLACK DRESS SHIRT HANGER WITH SWIVEL HOOK(HEAVY WEIGHT)
PACKING : 100/CTNS



WOOD HANGER



WH17C 17" WOOD (NATURAL) DRESS & SHIRT HANGERS WITH SWIVEL HOOK (SUPER HEAVY WEIGHT)

NATURAL

100

23.00



WH14C 14" WOOD (NATURAL) PANTS HANGER WITH SWIVEL HOOK (SUPER HEAVY WEIGHT)

NATURAL

100

28.00

Item	Description	Color	Pack	Wt
------	-------------	-------	------	----

SHOE RACKS



SHOERACK	FOLDING SHOE RACK FOR EASY STORAGE 8 - 48"(W) x 12"(D) SHELF 58" HEIGHT	CHROME	1	62.00
-----------------	---	--------	---	-------

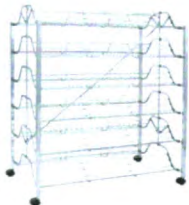

SHOERACK/2	FOLDING SHOE RACK FOR EASY STORAGE WITH CASTERS 12 - 48"(W) x 12"(D) SHELF 61" HEIGHT	CHROME	1	75.00
-------------------	--	--------	---	-------

SPECIALTY RACKS



R58	1 TIER REVOLVING BELT/TIE RACK 52" HEIGHT 20 - 3" HOOKS 18-1/2" BASE	CHROME	1	41.00
------------	---	--------	---	-------



R56	TWO TIER REVOLVING BELT/TIE RACK 54" HEIGHT UPPER RING 20 - 3" HOOKS LOWER RING 28 - 3" HOOKS 18-1/2" BASE	CHROME	1	46.00
------------	--	--------	---	-------

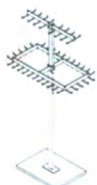

R98	3 LEVEL ADJUSTABLE BELT/TIE RACK 63" TO 72" HEIGHT UPPER LEVEL 16 - 3" HOOKS LOWER LEVEL 32 - 3" HOOKS 15-1/2" x 20-1/4" BASE	CHROME	1	46.00
------------	---	--------	---	-------



R29	SPIRAL RACK 65" HEIGHT 29 BALLS 18-1/2" BASE	CHROME	1	23.00
------------	---	--------	---	-------



R36	FOLDING LINGERIE TOWER - SQUARE TUBING W/ARMS 60" HEIGHT 16 - 3/8" x 12"(L) SQUARE TUBING TWIST-ON ARMS	CHROME	1	35.00
------------	--	--------	---	-------



R26	HAT DISPLAYER - 5 TIER SINGLE UPRIGHT 67" HEIGHT 18-1/2" BASE 20 HATS CAPACITY	CHROME	1	40.00
------------	---	--------	---	-------

	Item - Description	Color	Pack	Wt
--	--------------------	-------	------	----

SIGNHOLDERS FOR RACKS



MC57
MC711

7"W X 5-1/2"H SIGN HOLDER W/ 1/4" X 3/8" FITTING
11"W X 7-1/2"H SIGN HOLDER W/ 1/4" X 3/8" FITTING

CHROME
CHROME

25 9.00
25 14.00



PJ57
PJ711
PJ811

7"W X 5-1/2"H CLEAR SIGN HOLDER W/ 3/8" FITTING
11"W X 7-1/2"H CLEAR SIGN HOLDER W/ 3/8" FITTING
11"W X 8-1/2"H CLEAR SIGN HOLDER W/ 3/8" FITTING

CHROME
CHROME
CHROME

25 10.00
25 19.00
25 21.00



SC22

ALL PURPOSE CLAMPS

CHROME

100 13.00



M3
M6

3/8" X 3" THREADED STEM
3/8" X 6" THREADED STEM

CHROME
CHROME

100 10.00
100 20.00



NS3
NS6

3/8" X 3" SWEDGED STEM
3/8" X 6" SWEDGED STEM

CHROME
CHROME

100 10.00
100 20.00



MAG/S
MAG/T

90 DEGREE MAGNETIC CLAMP FITS 3/8" SWEDGE STEM
90 DEGREE MAGNETIC CLAMP FITS 3/8" THREADED
STEM

CHROME
CHROME

100 22.00
100 22.00



MAG/LS
MAG/LT

4" WIDE MAGNETIC BASE FITS 3/8" SWEDGE STEM
4" WIDE MAGNETIC BASE FITS 3/8" THREADED STEM

CHROME
CHROME

100 29.00
100 29.00

CASTERS



TW10
TW10/B

2" PLASTIC TWIN WHEEL CASTER W/ BLACK HOOD
2" PLASTIC TWIN WHEEL CASTER W/ BLACK HOOD
AND BRAKE - 3/8" & 5/16" THREAD AVAILABLE

BLACK
BLACK

100 18.00
100 18.00



CTM70
CTM70/B

2-1/2" CHROME HEAVY WEIGHT BALL CASTER
2-1/2" CHROME HEAVY WEIGHT BALL CASTER
W/ BRAKE 3/8" THREAD





50 36.00
50 36.00









HDC3
HDC3/B





3" HEAVY DUTY CASTER - 3/8" THREAD
3" HEAVY DUTY CASTER WITH BRAKE
- 3/8" THREAD

1 0.55
1 0.60

Item	Description	Color	Pack	Wt
 30GK52	30" ROUND X 3/16" TEMPER GLASS	GLASS	2	23.00
36GK57	36" ROUND X 3/16" TEMPER GLASS	GLASS	2	34.00
 00-013CH	30" ROUND BASKET FOR TOP OF ROUND RACKS R52WD & R57WD	CHROME	1	8.00
 KH5	ADD ON 36" DIAMETER ROUND HANGRAIL	CHROME	5	37.00
KH6	ADD ON 42" DIAMETER ROUND HANGRAIL	CHROME	5	43.00
KH8	ADD ON 36" DIAMETER RECTANGULAR HANGRAIL	CHROME	5	36.00
KH9	ADD ON 42" DIAMETER RECTANGULAR HANGRAIL	CHROME	5	41.00
 KH7	ADD ON BRACKET FOR ROUND RACKS - 4EA/SET	CHROME	5	37.00
 4PIN	TOP SHELF SUPPORT - 4EA/SET	CHROME	set	0.00

ROLLING RACKS

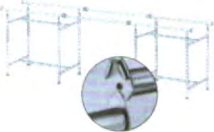
 RCS/1	HEAVY DUTY COLLAPSIBLE ROLLING RACK 48" HANGRAIL AND 2 - 12" PULL-OUT RODS	CHROME	1	28.00
 RCS/2	HEAVY DUTY COLLAPSIBLE DOUBLE ROLLING RACK 2 - 48" HANGRAIL AND 4 - 12" PULL-OUT RODS 22" WIDE	CHROME	1	35.00
 R43	SQ. TUBING SINGLE HANGRAIL ROLLING RACK 60" HANGRAIL x 20" WIDE 1-1/4" ROUND TUBING HANGRAIL	CHROME	1	29.00
 RZ/1	Z RACK - SQUARE TUBING	CHROME	1	35.00
RZ/1 (K/D)	Z RACK - SQUARE TUBING (KNOCK DOWN) 59" HANGRAIL x 68" HEIGHT	CHROME	1	35.00
 RZH/60	60" ADD-ON HANGRAIL FOR RZK/7 ROLLING RACK	CHROME	10	48.00
 RZE/12	12" HEIGHT EXTENSION FOR Z RACK	CHROME	10	15.00

	Item	Description	Color	Pack	Wt
H RACKS					
	R40	STANDARD H-RACK 60" HANGRAIL x 22" WIDE	CHROME	1	33.00
	R41	"H" RACK W/ V-BRACE 60" HANGRAIL x 22" WIDE	CHROME	1	42.00
	01-008CH	22"W X 54"L FOLDING TOP BASKET FOR H RACKS - R40 & R41	CHROME	1	16.00
	KH1	60" ADD-ON HANGRAIL FOR R40 & R41	CHROME	10	17.00
	KH2	60" DOUBLE HANGRAIL W/ CLAMP FOR -R40 & R41	CHROME	10	46.00
	KHZ	Z BRACE SUPPORT FOR R40	CHROME	10	37.00

ROUND RACKS



R52/WD	36" DIA ROUND FOLDING RACK WITH ROUND RING	CHROME	1	35.00
R52WD/MAB	4 - TOP SHELF SUPPORT INCLUDED	MATTE. BK	1	35.00



R57/WD	42" DIA ROUND FOLDING RACK WITH ROUND RING	CHROME	1	42.00
	4 - TOP SHELF SUPPORT INCLUDED			



R71/WD	36" DIA ROUND FOLDING RACK WITH RECT. RING	CHROME	1	35.00
R71/WD - SC	4 - TOP SHELF SUPPORT INCLUDED	SATIN CHROME	1	35.00

R73/WD	42" DIA ROUND FOLDING RACK WITH RECT. RING	CHROME	1	42.00
	4 - TOP SHELF SUPPORT INCLUDED			



Item	Description	Color	Pack	Wt
R23RT-SC	2-WAY W/ STRAIGHT BLADE ARMS RETANGULAR TUBING UPRIGHT 2 - 16" 1/2" x 1-1/2" RECT. TUBING STRAIGHT ARMS 12" x 15" HEAVY WEIGHTED BASE	SATIN CHROME	1	32.00



R24	2-WAY W/ SLANT BLADE ARMS - SQUARE TUBING 2 - 16" 1/2" x 1-1/2" RECT. TUBING SLANT ARMS WITH 8 BALLS 12" x 15" HEAVY WEIGHTED BASE	CHROME	1	33.00
-----	---	--------	---	-------

SQUARE TUBING ADD-ON ARMS



TV/12	12" TWIST-ON STRAIGHT ARM FOR SQUARE TUBING	CHROME	25	18.00
TV/16	16" TWIST-ON STRAIGHT ARM FOR SQUARE TUBING RACK - SQUARE TUBING FACEOUT	CHROME	25	22.00



TV/17	16" TWIST-ON STRAIGHT ARM FOR SQUARE TUBING RACK - RECTANGULAR TUBING FACEOUT	CHROME	25	31.00
-------	--	--------	----	-------

HIGH CAPACITY RECTANGULAR TUBING RACKS

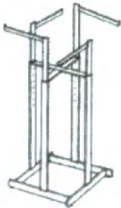

R80	RECT. TUBE 4-WAY W/ 4-22" STRAIGHT ARMS - SUPER QUAD 1 - 3/8" FITTING FOR SIGNHOLDER	CHROME	1	41.00
-----	--	--------	---	-------

R80 X 16	RECT. TUBE 4-WAY W/ 4-16" STRAIGHT ARMS	CHROME	1	39.00
R80 X 16-SC	- SUPER QUAD	SATIN CHROME	1	39.00
	1 - 3/8" FITTING FOR SIGNHOLDER			



R85	RECT. TUBE 4-WAY RACK W/ 4-16" STRAIGHT ARMS	CHROME	1	37.00
R85-SC	1 - 3/8" FITTING FOR SIGNHOLDER	SATIN CHROME	1	37.00



R66N	6 WAY RACK 6 - 16" Straight Arms 1/2" x 1 1/2" Rectangular Tubing Frame	CHROME	1	63.00
------	---	--------	---	-------

RECTANGULAR TUBING ADD-ON ARMS



RV/16	16" TWIST-ON STRAIGHT ARM FOR RECTANGULAR TUBING RACK	CHROME	25	33.00
RV/22	22" TWIST-ON STRAIGHT ARM FOR RECTANGULAR TUBING RACK	CHROME	25	41.00

Item	Description	Color	Pack	Wt
------	-------------	-------	------	----

1" SQUARE TUBING RACKS



R10 SQ. TUBING 4-WAY W/ 4 STRAIGHT
SQ. TUBE ARMS
4 - 16" STRAIGHT ARMS

CHROME

1

31.00



R12 SQ. TUBING 4-WAY WITH 2-SLANT
1/2-STRAIGHT SQ. TUBE
ARMS
2 - 16" STRAIGHT ARMS
2 - 18" SLANT ARMS WITH 8 BALLS

CHROME

1

33.00



R13 4-WAY W/ STRAIGHT BLADE ARMS
R13/MAB - SQUARE TUBING
R13-SC 4 - 16" 1/2" x 1-1/2" RECT.
TUBING STRAIGHT ARMS

CHROME

1

33.00

MT BLK

1

34.00

SATIN CHROME

1

33.00



R14 4-WAY W/ SLANT BLADE ARMS
- SQUARE TUBING
4 - 16" 1/2" x 1-1/2" RECT.
TUBING SLANT ARMS WITH
8 BALLS

CHROME

1

35.00



R15 SQ. TUBING 4-WAY RACK W
/ 4 SQ. TUBE SLANT ARMS
4 - 18" SLANT ARMS WITH 8 BALLS

CHROME

1

35.00



R20 SQ. TUBE 2-WAY W/ 2-STRAIGHT
SQ. TUBE ARMS 2 - 16" STRAIGHT ARMS
12" x 15" HEAVY WEIGHTED BASE

CHROME

1

26.00



R25 SQ. TUBE 2-WAY W/ 2-SLANT SQ. TUBE ARMS
2 - 18" SLANT ARMS WITH 8 BALLS
12" x 15" HEAVY WEIGHTED BASE

CHROME

1

26.00



R22 2-WAY W/ 1 STRAIGHT AND 1 SLANT ARM
1 - 16" STRAIGHT ARM
1 - 18" SLANT ARM WITH 8 BALLS
12" x 15" HEAVY WEIGHTED BASE

CHROME

1

28.00



R23 2-WAY W/ STRAIGHT BLADE ARMS
R23/MAB 2 - 16" 1/2" x 1-1/2" RECT.
TUBING STRAIGHT ARMS
12" x 15" HEAVY WEIGHTED BASE

CHROME

1

32.00

MATTE BLK

1

33.00



PL-K2
TWO WAY RACK

Height:
ADJUSTABLE
48"-72"

Base:
24 1/2" X 18 1/2"

Arms: 16" Long



PL-K2
BALLET BAR
RACK

Height:
ADJUSTABLE
48"-72"

Base:
48" X 23 1/2"

48" Wide



PL-RR
48" ROUND RACK

Height:
ADJUSTABLE
48"-72"

Base:
42" X 42"



PL-K4
FOUR WAY RACK

Height:
ADJUSTABLE
48"-72"

Base:
30" X 30"

Arms: 16" Long



PL-KH
H RACK

Height:
ADJUSTABLE
48"-72"

Base:
48" X 30"

48" Wide

**TOP BASKET
SOLD
SEPARATELY**



PL-HR
HALF ROUND
RACK

Height: 54"

Base:
35" X 35"



CASTER
3" CASTERS
LOCKING

Item - Description

Color

Pack

Wt

FOLDING DUMP TABLE

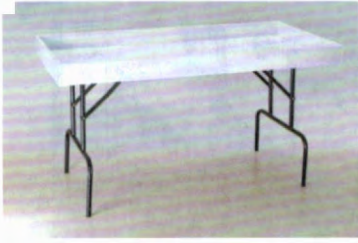

DBT/W
30" X 60" X 30" DUMP TABLE

WHITE

1

57.00

DISPLAY TABLES



T6032
60"(L) X 32"(W) X 30"(H)

SATIN CHR.

1

75.00

T5026
50"(L) X 26"(W) X 24"(H)
2" TUBING CONSTRUCTION
WITH LAMINATED MAPLE WOOD

SATIN CHR.

1

94.00



CT6050
60"(L) X 32"(W) X 30"(H)
50"(L) X 26"(W) X 24"(H)
1" x 1 1/2" TUBING CONSTRUCTION
WITH LAMINATED MAPLE WOOD

SILVER

1

148.00

WOOD DISPLAY TABLE



WDT-1(SET)
SMALL : 47"X23"X20"H TABLE
LARGE : 60"X32"X29"H TABLE

DARK CHERRY

2

126.00

DUMP BINS

Item	Description	Color	Pack	Wt
	DT3636 36"X36"X30" DUMP TABLE WITH CASTERS AND ADJUSTABLE WOOD SHELF	CHROME	1	88.00
	DT2840 28"X40"X30" FOLDING DUMP TABLE WITH CASTERS	CHROME	1	39.00
	DT2436 24"X36"X34" DUMP TABLE WITH CASTERS	CHROME	1	36.00
	DT48/W FOLDING DUMP TABLE WITH CASTERS	WHITE	1	39.00
	3332B 18" 3-TIER BIN - 45"(H)	BLACK	1	24.00
	3332W 18" 3-TIER BIN - 45"(H)	WHITE	1	24.00
	854C24 DUMP BIN - 23" X 23" X 33"(H)	CHROME	1	19.00
	SB4 STACKING BASKET 24"(W) x 20"(D) x 11"(H) 4 BASKETS casters included	CHROME	1	40.00

Item	Description	Color	Pack	Wt
------	-------------	-------	------	----

Saddle Mount Hardware



RH/12	12" RECTANGULAR FACE-OUT FOR	CHROME	25	24.00
RH/12-SC	RECTANGULAR HANGRAIL	SATIN CHROME	25	24.00
RH/12-MAB		MATTE BLK	25	24.00

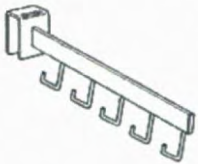

RH/5H	5-HOOK WATERFALL FOR RECTANGULAR HANGRAIL	CHROME	25	29.00
-------	---	--------	----	-------

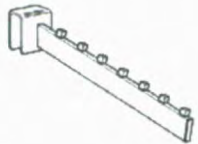

RH/7B	7-BALL WATERFALL FOR RECTANGULAR HANGRAIL	CHROME	25	36.00
-------	---	--------	----	-------



H4	4" HOOK FOR RECTANGULAR HANGRAIL	CHROME	100	15.00
H6	6" HOOK FOR RECTANGULAR HANGRAIL	CHROME	100	18.00
H9	9" HOOK FOR RECTANGULAR HANGRAIL	CHROME	100	26.00
H12	12" HOOK FOR RECTANGULAR HANGRAIL	CHROME	100	28.00
H4 - SC	4" HOOK FOR RECTANGULAR HANGRAIL	SATIN CHROME	100	15.00
H6 - SC	6" HOOK FOR RECTANGULAR HANGRAIL	SATIN CHROME	100	18.00
H9 - SC	9" HOOK FOR RECTANGULAR HANGRAIL	SATIN CHROME	100	26.00
H12 - SC	12" HOOK FOR RECTANGULAR HANGRAIL	SATIN CHROME	100	28.00

Wall Mount Hardware



TB/12	12" FACEOUT FOR WALL MOUNT	CHROME	25	10.00
-------	----------------------------	--------	----	-------

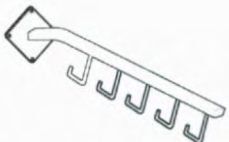

TB/7B	7-BALL WATERFALL FOR WALL MOUNT	CHROME	25	28.00
-------	---------------------------------	--------	----	-------

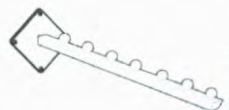

TB/5H	5-HOOK WATERFALL FOR WALL MOUNT	CHROME	25	28.00
-------	---------------------------------	--------	----	-------

Item	Description	Color	Pack	Wt
------	-------------	-------	------	----

TUBING & ACCESSORIES



RE2	2'L X 1/2" X 1-1/2" RECTANGULAR TUBING	CHROME	10	15.00
RE2-SC		SATIN CHROME	10	15.00
RE3	3'L X 1/2" X 1-1/2" RECTANGULAR TUBING	CHROME	10	28.00
RE3-SC		SATIN CHROME	10	28.00
RE4	4'L X 1/2" X 1-1/2" RECTANGULAR TUBING	CHROME	10	28.00
RE4/MAB		MATTE BLK	10	36.00
RE4-SC		Stn Chr	10	36.00
RE5	5'L X 1/2" X 1-1/2" RECTANGULAR TUBING	CHROME	10	40.00
RE6	6'L X 1/2" X 1-1/2" RECTANGULAR TUBING	CHROME	10	45.00
RE8	8'L X 1/2" X 1-1/2" RECTANGULAR TUBING	CHROME	5	26.00
RE10	10'L X 1/2" X 1-1/2" RECTANGULAR TUBING	CHROME	5	36.00
RE12	12'L X 1/2" X 1-1/2" RECTANGULAR TUBING	CHROME	5	44.00



RU4	4'L ROUND TUBING - 1" DIA	CHROME	10	33.00
RU6	6'L ROUND TUBING - 1" DIA	CHROME	10	50.00
RU8	8'L ROUND TUBING - 1" DIA	CHROME	10	68.00
RU10	10'L ROUND TUBING - 1" DIA	CHROME	5	43.00
RU12	12'L ROUND TUBING - 1" DIA	CHROME	5	53.00



RX4	4'L ROUND TUBING - 1-1/8" DIA	CHROME	10	37.00
RX6	6'L ROUND TUBING - 1-1/8" DIA	CHROME	10	55.00
RX8	8'L ROUND TUBING - 1-1/8" DIA	CHROME	10	71.00



RY4	4'L ROUND TUBING - 1-1/4" DIA	CHROME	10	40.00
RY6	6'L ROUND TUBING - 1-1/4" DIA	CHROME	10	60.00
RY8	8'L ROUND TUBING - 1-1/4" DIA	CHROME	10	75.00
RY10	10'L ROUND TUBING - 1-1/4" DIA	CHROME	5	51.00
RY12	12'L ROUND TUBING - 1-1/4" DIA	CHROME	5	58.00



EC4	END CAPS FOR 1/2" X 1-1/2" RECTANGULAR TUBING	CHROME	100	10.00
EC4/MAB		MATTE BLK	100	10.00
EC4-SC		SATIN CHROME	100	10.00



EC5	EXTENDED END CAP FOR 1/2" X 1-1/2" RECTANGULAR	CHROME	100	14.00
-----	--	--------	-----	-------



EC1	END CAP FOR 1" & 1-1/16" ROUND TUBING	CHROME	100	10.00
EC2	END CAP FOR 1-1/4" ROUND TUBING	CHROME	100	10.00



RE/SP	SPLICER FOR 1/2" x 1-1/2" RECTANGULAR TUBING	ZINC	100	10.00
-------	--	------	-----	-------



RU/SP	SPLICER FOR 1" ROUND TUBE	ZINC	100	11.00
RY/SP	SPLICER for 1 1/4" ROUND TUBE	ZINC	100	13.00

Item	Description	Color	Pack	Wt
------	-------------	-------	------	----

HEAVY DUTY STANDARD



SS30/48	48" H.D SINGLE SLOT W/ 1" SLOTS ON 2" CENTERS	SATIN ZINC	10	40.00
SS30/60	60" H.D SINGLE SLOT W/ 1" SLOTS ON 2" CENTERS	SATIN ZINC	10	40.00
SS30/72	72" H.D SINGLE SLOT W/ 1" SLOTS ON 2" CENTERS	SATIN ZINC	10	46.00
SS30/84	84" H.D SINGLE SLOT W/ 1" SLOTS ON 2" CENTERS	SATIN ZINC	10	54.00
SS30/96	96" H.D SINGLE SLOT W/ 1" SLOTS ON 2" CENTERS	SATIN ZINC	10	62.00
SS30/120	120" H.D SINGLE SLOT W/ 1" SLOTS ON 2" CENTERS	SATIN ZINC	10	62.00
SS30/144	144" H.D SINGLE SLOT W/ 1" SLOTS ON 2" CENTERS	SATIN ZINC	10	62.00

RECESSED SLOTTED STANDARD(1" SLOT 2" ON CENTER)



40-106ZC	6'H X 11/16"D RECESSED STANDARD	ZINC	8	42.00
40-108ZC	8'H X 11/16"D RECESSED STANDARD	ZINC	4	27.00

HEAVY DUTY STANDARDS BRACKETS



G10	10" SHELF BRACKET FOR 1" ON 2" CENTER S.S	ZINC	25	21.00
G12	12" SHELF BRACKET FOR 1" ON 2" CENTER S.S	ZINC	25	21.00
G14	14" SHELF BRACKET FOR 1" ON 2" CENTER S.S	ZINC	25	25.00
G16	16" SHELF BRACKET FOR 1" ON 2" CENTER S.S	CHROME	25	28.00
G18	18" SHELF BRACKET FOR 1" ON 2" CENTER S.S	CHROME	25	33.00

RECESSED SLOTTED STANDARD - BRACKETS (FOR 1" HEAVY DUTY)



43-033CH	BRACKET FOR SHELF 12"	CHROME	25	12.00
43-034CH	BRACKET FOR SHELF 14"	CHROME	25	14.00
43-035CH	BRACKET FOR SHELF 16"	CHROME	25	16.00



GR3	3" RECT. HANGRAIL BRACKET FOR 1" SLOT ON	CHROME	25	15.00
GR3/MAB	2" CENTER	MATTE BLK	25	15.00
GR3-SC		SATIN CHROME	25	15.00



GR12	12" RECT. HANGRAIL BRACKET FOR 1" SLOT ON	CHROME	25	28.00
GR12/MAB	2" CENTER	MATTE BLK	25	28.00
GR12-SC		SATIN CHROME	25	28.00
GR14	14" RECT. HANGRAIL BRACKET FOR 1" SLOT ON	CHROME	25	
	2" CENTER			





RR3	3" RECT. TUBING FACE-OUT FOR 1" SLOT ON	CHROME	25	13.00
RR/12	12" RECT. TUBING FACE-OUT FOR 1" SLOT ON	CHROME	25	23.00
RR/12-SC	2" CENTER	SATIN CHROME	25	23.00
RR/14	14" RECT. TUBING FACE-OUT FOR 1" SLOT ON	CHROME	25	26.00



RR/5H	5-HOOK WATERFALL FOR 1" SLOT ON 2" CENTER	CHROME	25	44.00
-------	---	--------	----	-------

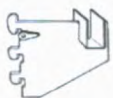

RR/7B	7-CUBE WATERFALL FOR 1" SLOT ON 2" CENTER	CHROME	25	37.00
-------	---	--------	----	-------

Item	Description	Color	Pack	Wt
MEDIUM STANDARDS SADDLE BRACKET				
 CR3	3" RECT. HANGRAIL BRKT. FOR 1/2" SLOT ON 1"	CHROME	25	12.00
CR3/MAB	CENTER	MATTE BLK	25	12.00
CR3/SC		SATIN CHROME	25	12.00
 CR12	12" RECT. HANGRAIL BRKT FOR 1/2" SLOT ON 1"	CHROME	25	27.00
CR12/MAB	CENTER	MATTE BLK	25	27.00
CR12/SC		SATIN CHROME	25	27.00
 CR6	6" RECT. HANGRAIL BRKT FOR 1/2" SLOT ON 1" CENTER	CHROME	25	23.00
CR8	8" RECT. HANGRAIL BRKT FOR 1/2" SLOT ON 1" CENTER	CHROME	25	25.00
CR14	12" RECT. HANGRAIL BRKT FOR 1/2" SLOT ON 1" CENTER	CHROME	25	28.00

MEDIUM STANDARDS FACEOUT & WATERFALL

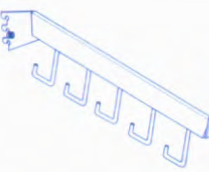
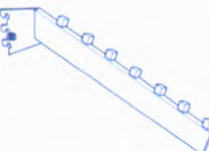
 TS12	12" STRAIGHT FACEOUT - SQUARE TUBING	CHROME	25	14.00
 TS/5H	5-HOOKS WATERFALL - SQUARE TUBING	CHROME	25	26.00
 TS/7B	7-BALL WATERFALL - SQUARE TUBING	CHROME	25	26.00
 RDW12	12" RECT TUBING STRAIGHT FACEOUT	CHROME	25	23.00
 RDW/5H	5-HOOK WATERFALL - RECTANGULAR TUBING	CHROME	25	33.00
 RDW/7B	7-BALL WATERFALL - RETANGULAR TUBING	CHROME	25	33.00

MEDIUM DUTY STANDARDS



Item	Description	Color	Pack	Wt
SS10/36	36" M.D SINGLE SLOT W/ 1/2" SLOTS ON 1" CENTERS	SATIN ZINC	10	11.00
SS10/48	48" M.D SINGLE SLOT W/ 1/2" SLOTS ON 1" CENTERS	SATIN ZINC	10	13.00
SS10/60	60" M.D SINGLE SLOT W/ 1/2" SLOTS ON 1" CENTERS	SATIN ZINC	10	15.00
SS10/72	72" M.D SINGLE SLOT W/ 1/2" SLOTS ON 1" CENTERS	SATIN ZINC	10	18.00
SS10/84	84" M.D SINGLE SLOT W/ 1/2" SLOTS ON 1" CENTERS	SATIN ZINC	10	22.00
SS10/96	96" M.D SINGLE SLOT W/ 1/2" SLOTS ON 1" CENTERS	SATIN ZINC	10	23.00



SS20/60	60" M.D DOUBLE SLOT W/ 1/2" SLOTS ON 1" CENTERS	SATIN ZINC	10	22.00
SS20/72	72" M.D DOUBLE SLOT W/ 1/2" SLOTS ON 1" CENTERS	SATIN ZINC	10	26.00
SS20/84	84" M.D DOUBLE SLOT W/ 1/2" SLOTS ON 1" CENTERS	SATIN ZINC	10	30.00
SS20/96	96" M.D DOUBLE SLOT W/ 1/2" SLOTS ON 1" CENTERS	SATIN ZINC	10	33.00



TCSS	TOP CLIP TO HOLD STANDARD FOR SHOWCASE	CHROME	100/PK	2.00
------	--	--------	--------	------



BCSS	BOTTOM CLIP TO HOLD STANDARD FOR SHOWCASE	CHROME	100/PK	2.00
------	---	--------	--------	------

MEDIUM STANDARDS BRACKETS



GA6	6" TAP-IN STYLE SHELF BRACKET	NICKEL	25	7.00
GA8	8" TAP-IN STYLE SHELF BRACKET	NICKEL	25	8.00
GA10	10" TAP-IN STYLE SHELF BRACKET	NICKEL	25	7.00
GA12	12" TAP-IN STYLE SHELF BRACKET	NICKEL	25	8.00
GA14	14" TAP-IN STYLE SHELF BRACKET	NICKEL	25	9.00
GA16	16" TAP-IN STYLE SHELF BRACKET	NICKEL	25	9.00



A112	1" & 1-1/16" ROUND TUBING HANGRAIL B/K	CHROME	25	22.00
A212	1-1/4" ROUND TUBING HANGRAIL B/K	CHROME	25	22.00

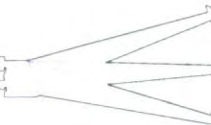

GC12	ADJUSTABLE SHELF BRACKET - 12"	CHROME	25	14.00
GC14	ADJUSTABLE SHELF BRACKET - 14"	CHROME	25	15.00



WBL12	WOOD SHELF BRACKET - 12" LEFT	SATIN ZINC	25	18.00
WBL14	WOOD SHELF BRACKET - 14" LEFT	SATIN ZINC	25	19.00
WBL16	WOOD SHELF BRACKET - 16" LEFT	SATIN ZINC	25	20.00
WBR12	WOOD SHELF BRACKET - 12" RIGHT	SATIN ZINC	25	18.00
WBR14	WOOD SHELF BRACKET - 14" RIGHT	SATIN ZINC	25	19.00
WBR16	WOOD SHELF BRACKET - 16" RIGHT	SATIN ZINC	25	20.00
WBC12	WOOD SHELF BRACKET - 12" CENTER	SATIN ZINC	25	19.00
WBC14	WOOD SHELF BRACKET - 14" CENTER	SATIN ZINC	25	20.00
WBC16	WOOD SHELF BRACKET - 16" CENTER	SATIN ZINC	25	21.00

BRACKET ACCESSORIES



LKC	DELUXE STYLE SNAP-IN CENTER SHELF REST	SATIN ZINC	1000	15.00
-----	--	------------	------	-------



BU	RUBBER BUMPER		1000	1.00
----	---------------	--	------	------

Item	Description	Color	Pack	Wt
------	-------------	-------	------	----

ALL-PURPOSE VIDEO SHELF

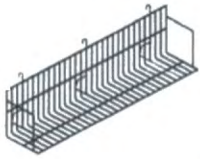

VS24 - B
VS24 - W

24"(W) - BLACK VIDEO SHELF FOR GRIDWALL/SLATWALL
24"(W) - WHITE VIDEO SHELF FOR GRIDWALL/SLATWALL

BLACK
WHITE

10
10

14.00
14.00

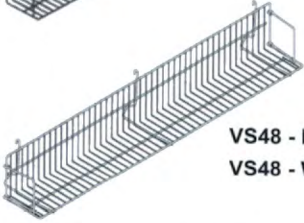

VS48 - B
VS48 - W

48"(W) - BLACK VIDEO SHELF FOR GRIDWALL/SLATWALL
48"(W) - WHITE VIDEO SHELF FOR GRIDWALL/SLATWALL

BLACK
WHITE

10
10

27.00
27.00

ALL-PURPOSE BASKETS



BSK11/C
BSK11/B
BSK11/W

24"W X 12"D X 4"H SHALLOW BASKET

CHROME
BLACK
WHITE

6
6
6

16.00
16.00
16.00



BSK12/C
BSK12/B
BSK12/W

24"W X 10"D X 5"H DOUBLE SLOPING BASKET

CHROME
BLACK
WHITE

6
6
6

18.00
18.00
18.00



BSK13/C
BSK13/B
BSK13/W

12"W X 12"D X 4"H SMALL BASKET

CHROME
BLACK
WHITE

6
6
6

10.00
10.00
10.00



BSK14/C
BSK14/B
BSK14/W

12"W X 12"D X 8"H SLOPED FRONT BASKET

CHROME
BLACK
WHITE

6
6
6

11.00
11.00
11.00



BSK15/C
BSK15/B
BSK15/W

12"W X 12"D X 8"H DEEP BASKET

CHROME
BLACK
WHITE

6
6
6

14.00
14.00
14.00



BSK16/C
BSK16/B
BSK16/W

15"W X 12"D X 5"H SLOPING BASKET

CHROME
BLACK
WHITE

6
6
6

10.00
10.00
10.00



BSK17/C
BSK17/B
BSK17/W

12"W X 6"D X 6"H NARROW BASKET

CHROME
BLACK
WHITE

6
6
6

9.00
9.00
9.00

Item	Description	Color	Pack	Wt
------	-------------	-------	------	----

ALL-PURPOSE 24" X 12" BASKETS



SLOPED FRONT BASKET
BSK20/B
BSK20/W
 6" BACK & 2" FRONT

BLACK
 WHITE

6 14.00
 6 14.00

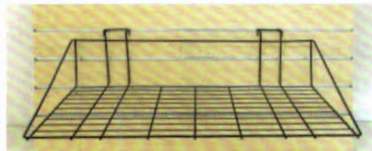

SLANT SHELF
BSK21/B
BSK21/W
 2" LIP FRONT

BLACK
 WHITE

6 11.00
 6 11.00

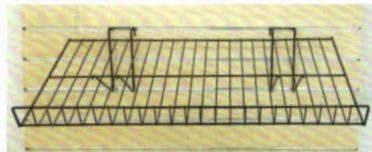

FLAT FRONT SHELF
BSK22/B
BSK22/W
 6" BACK & 2" FRONT

BLACK
 WHITE

6 12.00
 6 12.00

Item**Description****Color****Pack****Wt**

GRID CONNECTOR & WALL MOUNT

**GW/JC**
GWB/JC
GWW/JC

JOINING CLIP

CHROME
BLACK
WHITE1000
1000
100036.00
36.00
36.00**GW/WB**
GWB/WB
GWW/WB

WALLMOUNT BRACKET FOR GRIDWALL





CHROME
BLACK
WHITE100
100
10033.00
33.00
33.00**GW/FRC**

3" FACEOUT W/ DISC AT END

CHROME

50

21.00

Item	Description	Color	Pack	Wt	
GRID HANGRAIL					
	KHG680	QUARTER CIRCLE 1-1/4" ROUND TUBING HANGRAIL	CHROME	10	28.00
	KHGB680	WITH CHROME STRIP	BLACK	10	30.00
	KHGW680	WITH CHROME STRIP	WHITE	10	30.00
	KHG681	U-SHAPED 1-1/4" ROUND TUBING HANGRAIL	CHROME	10	29.00
	KHGB681	WITH CHROME STRIP	BLACK	10	31.00
	KHGW681	WITH CHROME STRIP	WHITE	10	31.00
	GW/RM	12" HANGRAIL B/K FOR 1" & 1-1/16" ROUND HANGRAIL	CHROME	25	30.00
	GW/RT	12" HANGRAIL B/K FOR 1-1/4" ROUND HANGRAIL	CHROME	25	30.00
	GW/ML	MILLINERY DISPLAYER	CHROME	25	15.00
	GWB/ML		BLACK	25	15.00
	GWW/ML		WHITE	25	15.00



GRIDWALL SHELF



	GP2412	24"X12" SHELF	CHROME	6	27.00
	GPB2412		BLACK	6	27.00
	GPW2412		WHITE	6	27.00

TRIANGULAR SHELF

	16-001CH	24"X24"X34-1/2" TRIANGULAR SHELF	CHROME	5	19.00
	16-001BL	24"X24"X34-1/2" TRIANGULAR SHELF	BLACK	5	19.00
	16-001WH	24"X24"X34-1/2" TRIANGULAR SHELF	WHITE	5	19.00

GRIDWALL CAP DISPLAYER

	GP/CAP	1/8" WIRE CAP DISPLAYER	CHROME	50	20.00
	GPB/CAP		BLACK	50	20.00
	GPW/CAP		WHITE	50	20.00
	GP/CAP-S	WIRE CAP DISPLAYER	CHROME	20	15.00
	GPB/CAP-S	holds 12 CAPS	BLACK	20	15.00
	GPW/CAP-S		WHITE	20	15.00



Item	Description	Color	Pack	Wt	
GRID HOOKS					
	GW/NHK	NOTCH HOOK	CHROME	100	11.00
	GWB/NHK		BLACK	100	11.00
	GWW/NHK		WHITE	100	11.00
	GW/H1	1" HOOK	CHROME	100	15.00
	GWB/H1		BLACK	100	15.00
	GWW/H1		WHITE	100	15.00
	GW/H2	2" HOOK	CHROME	100	17.00
	GWB/H2		BLACK	100	17.00
	GWW/H2		WHITE	100	17.00
	GW/H4	4" HOOK	CHROME	100	17.00
	GWB/H4		BLACK	100	17.00
	GWW/H4		WHITE	100	17.00
	GW/H6	6" HOOK	CHROME	100	21.00
	GWB/H6		BLACK	100	21.00
	GWW/H6		WHITE	100	21.00
	GW/H8	8" HOOK	CHROME	100	24.00
	GWB/H8		BLACK	100	24.00
	GWW/H8		WHITE	100	24.00
	GW/H10	10" HOOK	CHROME	100	26.00
	GWB/H10		BLACK	100	26.00
	GWW/H10		WHITE	100	26.00
	GW/H12	12" HOOK	CHROME	100	28.00
	GWB/H12		BLACK	100	28.00
	GWW/H12		WHITE	100	28.00

GRID BRACKETS

	GW/8KB	8" KNIFE BRACKET	CHROME	50	25.00
	GWB/8KB		BLACK	50	25.00
	GWW/8KB		WHITE	50	25.00
	GW/10KB	10" KNIFE BRACKET	CHROME	50	27.00
	GWB/10KB		BLACK	50	27.00
	GWW/10KB		WHITE	50	27.00
	GW/12KB	12" KNIFE BRACKET	CHROME	50	29.00
	GWB/12KB		BLACK	50	29.00
	GWW/12KB		WHITE	50	29.00
	GW/14KB	14" KNIFE BRACKET	CHROME	50	31.00
	GWB/14KB		BLACK	50	31.00
	GWW/14KB		WHITE	50	31.00

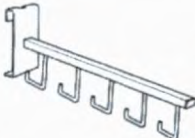

GRID FACEOUTS

	GW/11	12" SQ. TUBE 12" FACE-OUT	CHROME	25	8.00
	GWB/11		BLACK	25	8.00
	GWW/11		WHITE	25	8.00
	GW/5H	5-HOOK WATERFALL	CHROME	25	33.00
	GWB/5H		BLACK	25	33.00
	GWW/5H		WHITE	25	33.00
	GW/7B	SQ. TUBE 7-BALL WATERFALL	CHROME	25	29.00
	GWB/7B		BLACK	25	29.00
	GWW/7B		WHITE	25	29.00

Item	Description	Color	Pack	Wt
------	-------------	-------	------	----

GRID PANELS

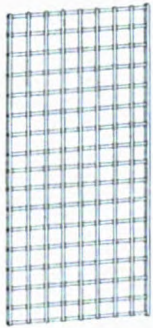

GW15	1' X 5' GRIDWALL	CHROME	3	29.00
GWB15	(CONSTRUCTED WITH 1/4" WIRE)	BLACK	3	29.00
GWW15		WHITE	3	29.00
GW24	2' X 4' GRIDWALL	CHROME	3	36.00
GWB24	(CONSTRUCTED WITH 1/4" WIRE)	BLACK	3	36.00
GWW24		WHITE	3	36.00
GW25	2' X 5' GRIDWALL	CHROME	3	45.00
GWB25	(CONSTRUCTED WITH 1/4" WIRE)	BLACK	3	45.00
GWW25		WHITE	3	45.00
GW26	2' X 6' GRIDWALL	CHROME	3	53.00
GWB26	(CONSTRUCTED WITH 1/4" WIRE)	BLACK	3	53.00
GWW26		WHITE	3	53.00
GW27	2' X 7' GRIDWALL	CHROME	3	63.00
GWB27	(CONSTRUCTED WITH 1/4" WIRE)	BLACK	3	63.00
GWW27		WHITE	3	93.00
GW28	2' X 8' GRIDWALL	CHROME	3	73.00
GWB28	(CONSTRUCTED WITH 1/4" WIRE)	BLACK	3	73.00
GWW28		WHITE	3	73.00
GW44	4' X 4' GRIDWALL	CHROME	3	70.00
GWB44	(CONSTRUCTED WITH 1/4" WIRE)	BLACK	3	70.00
GWW44		WHITE	3	70.00

SLATGRID PANEL



Item	Description	Color	Pack	Wt
	(CONSTRUCTED WITH 1/4" WIRE)			
STG26/C	2'X6' SLATGRID PANEL - CHROME	CHROME	3	64.00
STG26/B	2'X6' SLATGRID PANEL - BLACK	BLACK	3	64.00
STG28/C	2'X8' SLATGRID PANEL - CHROME	CHROME	3	89.00
STG28/B	2'X8' SLATGRID PANEL - BLACK	BLACK	3	89.00

GRID LEGS & BASES

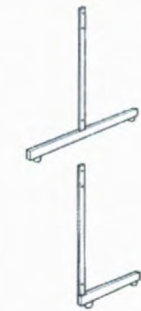

GL24/C	"T" LEG FOR GRIDWALL WITH LEVELERS	CHROME	12	40.00
GL24/B		BLACK	12	40.00
GL24/W		WHITE	12	40.00



GPL12	12" LEG FOR GRIDWALL WITH LEVELERS	CHROME	12	24.00
GPL12/B		BLACK	12	24.00
GPL12/W		WHITE	12	24.00

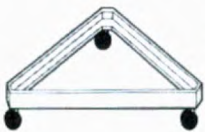

GW/3TB	TRIANGLE BASE FOR GRIDWALL WITH CASTERS	CHROME	1	8.00
GWB/3TB		BLACK	1	8.00
GWW/3TB		WHITE	1	8.00

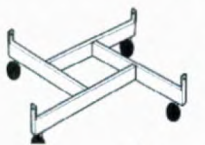

GW/4BA	4-WAY BASE FOR GRIDWALL WITH CASTERS	CHROME	1	11.00
GWB/4BA		BLACK	1	11.00
GWW/4BA		WHITE	1	11.00



GW/G48	GONDOLA BASE FOR GRIDWALL WITH LEVELERS	CHROME	1	13.00
GWB/G48		BLACK	1	13.00
GWW/G48		WHITE	1	13.00

RDJ ENTERPRISES

SPEED RAIL AND GARMENT RACKS
STEEL PARTITION AND SHELVING

361 W. 36th Street, New York, NY 10018

TED STEEL
Tel: 212-279-3878

ALL RACKS
Tel: 212-244-1069

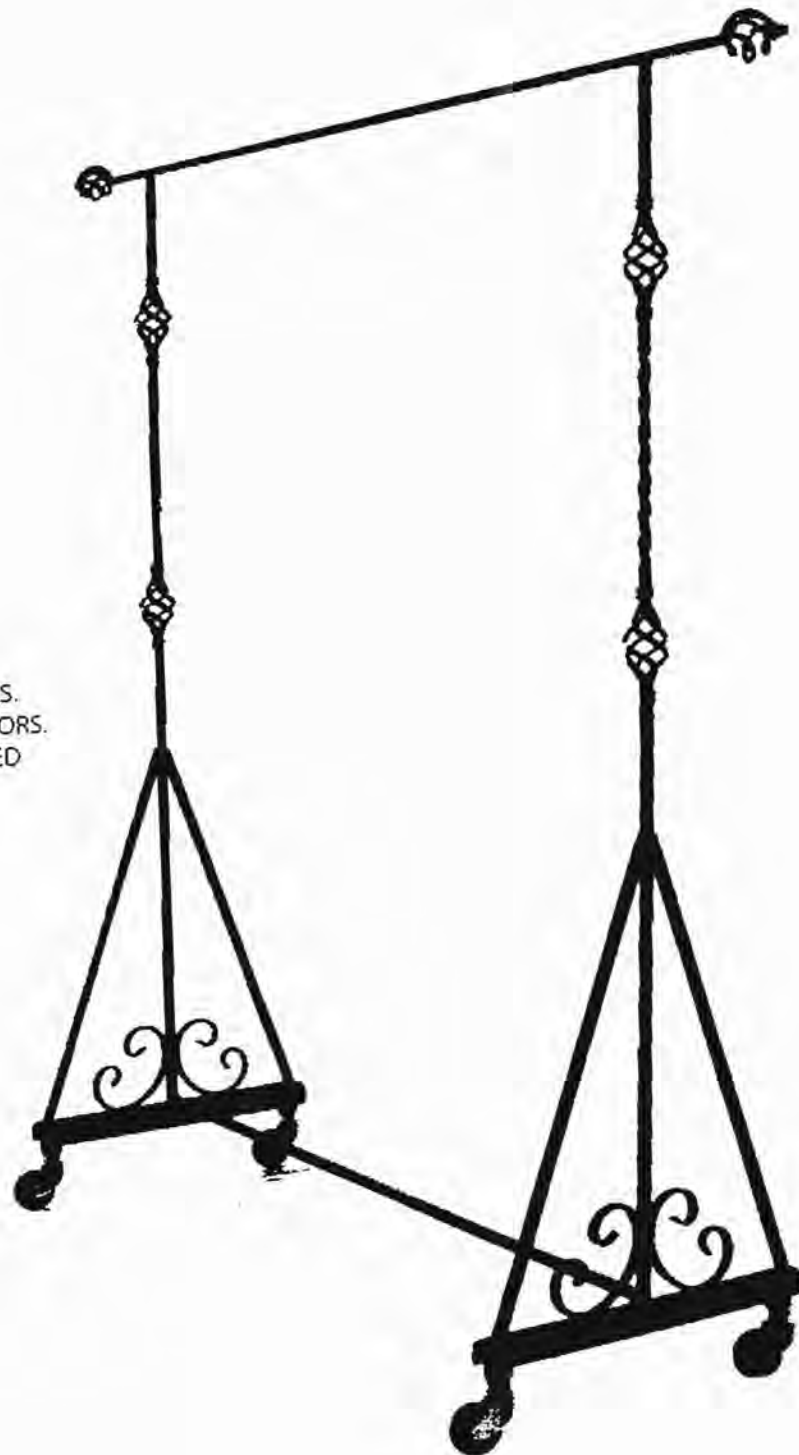

COSTUME MADE
WROUGHT IRON RACKS.
AVAILABLE IN MANY COLORS.
BLACK POWDER COATED
AS SHOWN.

RD J ENTERPRISES

SPEED RAIL AND GARMENT RACKS
STEEL PARTITION AND SHELVING

361 W. 36th Street, New York, NY 10018

ALL RACKS
Tel: 212-244-1069

TED STEEL
Tel: 212-279-3878

COSTUME MADE
WROUGHT IRON RACKS.
AVAILABLE IN MANY COLORS.
BLACK POWDER COATED
AS SHOWN.

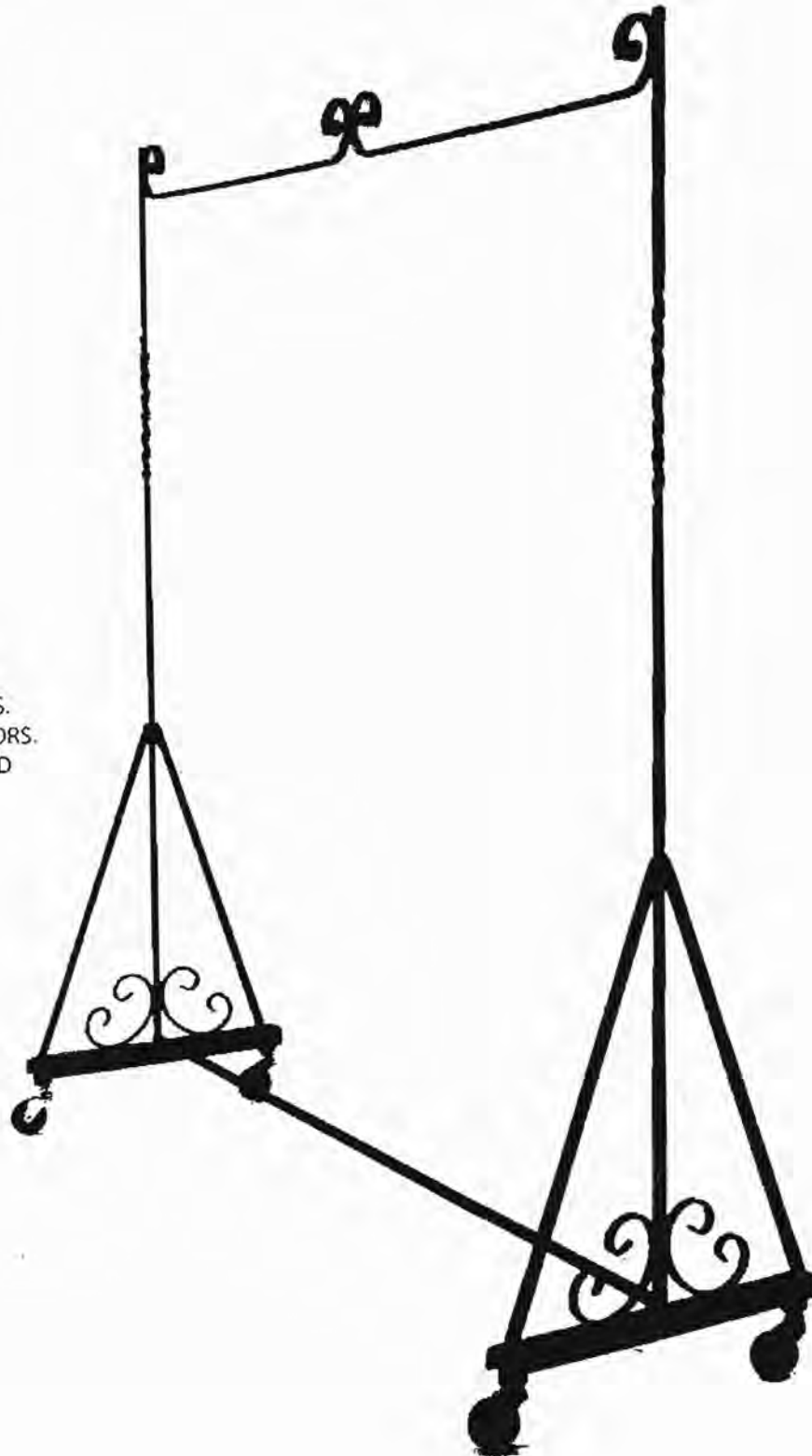

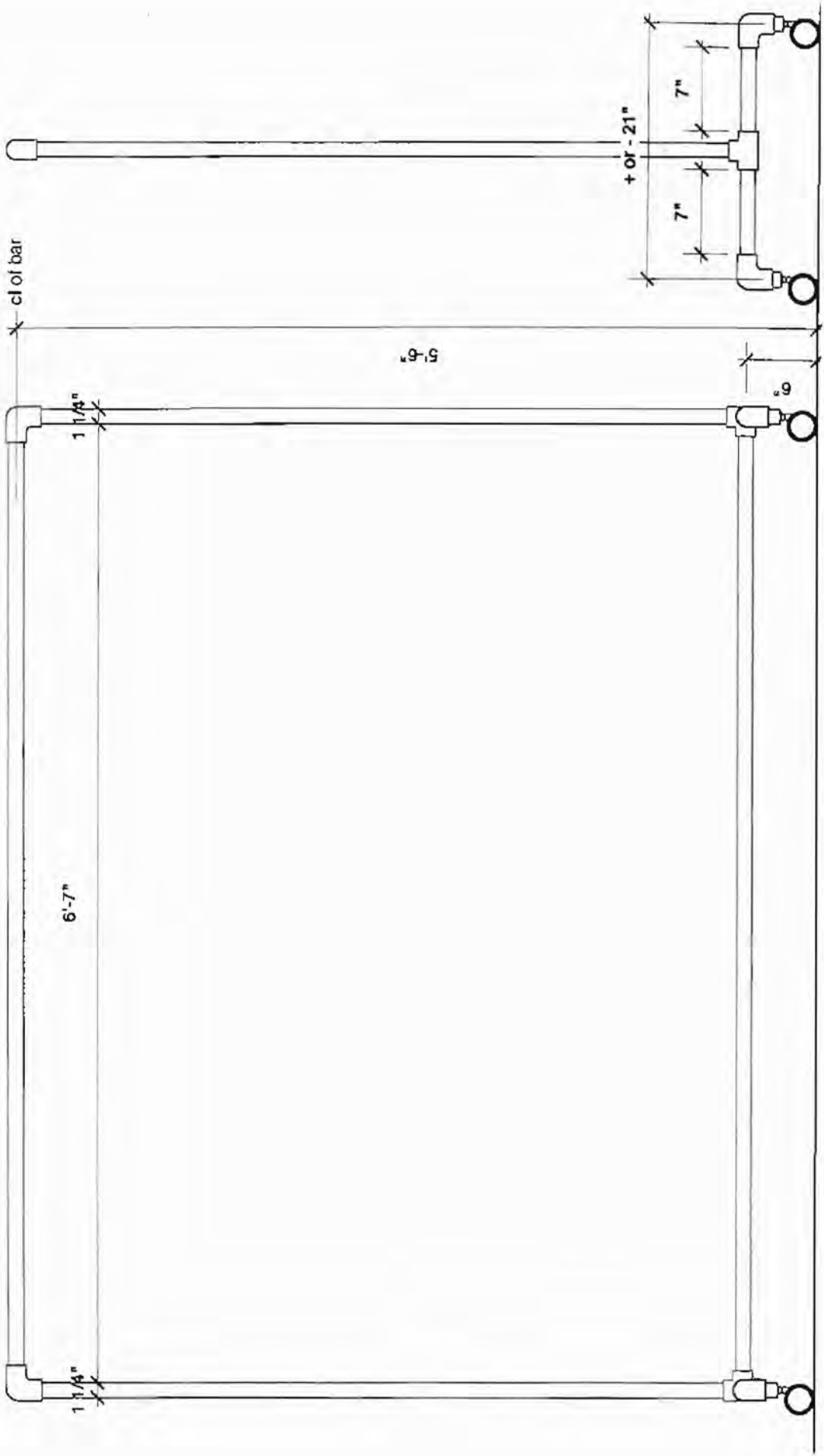

**Standard Piece Goods Truck
MODEL "A"**

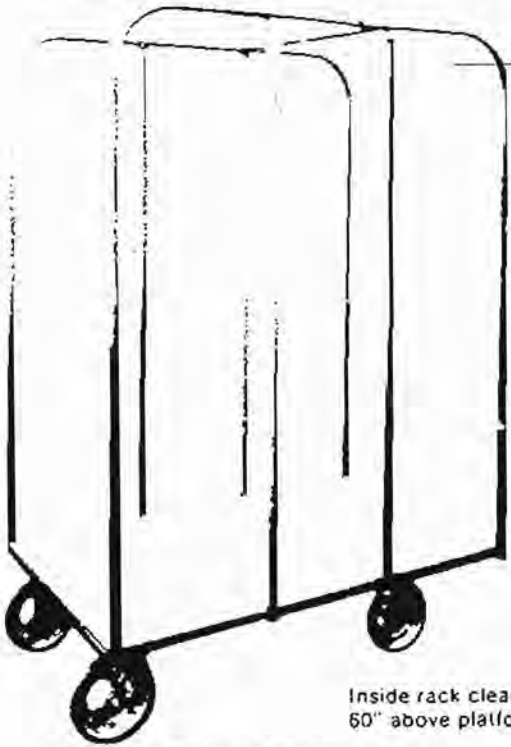

Inside rack clearance
60" above platform

**HIGH CENTER-BOW
PIECE GOODS TRUCK MODEL "B"**

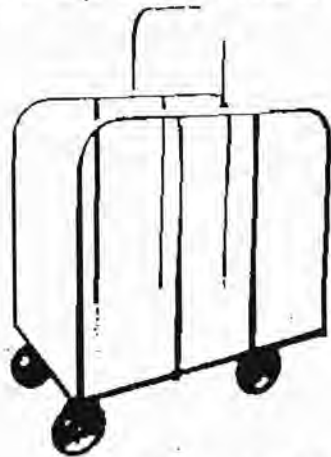

Inside Bow Clearance
60" above Platform

Side Rack Height —
45" above Platform.

**LOW SIDE RACK
PIECE GOODS TRUCK MODEL "C"**



Side Rack height 36
above platform.

All Steel Welded
Construction

Pipe size 1-5/16"
O.D. on all units

TED STEEL INDUSTRIES LTD
SPEED RAIL AND GARMENT RACKS
STEEL PARTITION AND SHELVING

361 W. 36th Street
New York, NY 10018

MODEL "A"

	6" Caster	8" Caster
24 x 36		
24 x 42		
24 x 48		
24 x 54		
24 x 60		
30 x 36		
30 x 42		
30 x 48		
30 x 54		
30 x 60		
36 x 36		
36 x 42		
36 x 48		
36 x 54		
36 x 60		

MODEL "B"

	6" Caster	8" Caster
24 x 36		
24 x 42		
24 x 48		
24 x 54		
24 x 60		
30 x 36		
30 x 42		
30 x 48		
30 x 54		
30 x 60		
36 x 36		
36 x 42		
36 x 48		
36 x 54		
36 x 60		

MODEL "C"

	6" Caster	8" Caster
24 x 36		
24 x 42		
24 x 48		
24 x 54		
24 x 60		
30 x 36		
30 x 42		
30 x 48		
30 x 54		
30 x 60		
36 x 36		
36 x 42		
36 x 48		
36 x 54		
36 x 60		

RDJ ENTERPRISES

SPEED RAIL AND GARMENT RACKS
STEEL PARTITION AND SHELVING

361 W. 36th Street, New York, NY 10018

ALL RACKS
Tel: 212-244-1069

TED STEEL
Tel: 212-279-3878

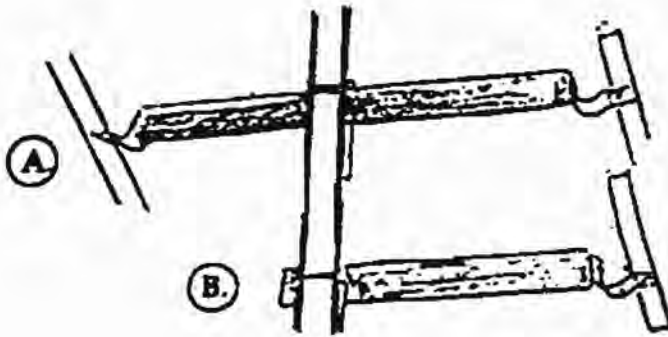

- A. DOUBLE ARM BRACKETS SPECIFY
For 1-5/16" O.D. or 1-5/8" O.D. Upright
- 18"
- 24"
- 27"
- 30"
- 36"

- B. SINGLE ARM BRACKET (Specify Upright)
- 9"
- 12"
- 13-1/2"
- 15"
- 18"

- C. PLATES ONLY FOR ARMS
- 1-5/16" tube
- 1-5/8"

- D. JACKS and FLOOR MOUNTS
- Top Only - 3/4" for 1-5/16" tube
- 1" for 1-5/8" tube
- Wood dowels either side
- Fish Plates
- 3/4" nipple and flange
- 1" nipple and flange
- 3/4" steel flange
- 1" steel flange

- E. BRACE CLAMPS
- 3/4" x 3/4"
- 1" x 3/4"
- 1-1/4" x 3/4"
- 1" x 1"
- 1-1/4" x 1"
- 1-1/4" x 1-1/4"
- 3/4" x 3/4" cross clamp
- 1" x 3/4" cross clamp
- 1" x 1" cross clamp
- 3/4" x 3/4" outside cross clamp
- 1" x 1" outside cross clamp
- 1-1/4" x 1-1/4" outside cross clamp

- E. FLANGE CLAMPS
- 3/4"
- 1"

- G. RAIL SUPPORTS
- Steel

- H. ANGLE BASE WELDED ROLLING RACKS
with 4" casters
- 4" casters (set of 4)

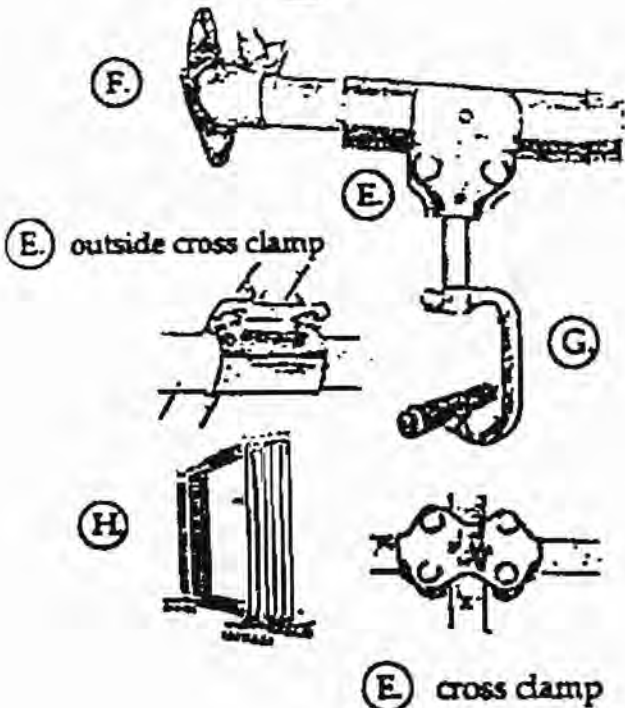

R D J ENTERPRISES

SPEED RAIL AND GARMENT RACKS
STEEL PARTITION AND SHELVING

361 W. 36th Street, New York, NY 10018

ALL RACKS
Tel: 212-244-1069

TED STEEL
Tel: 212-279-3878

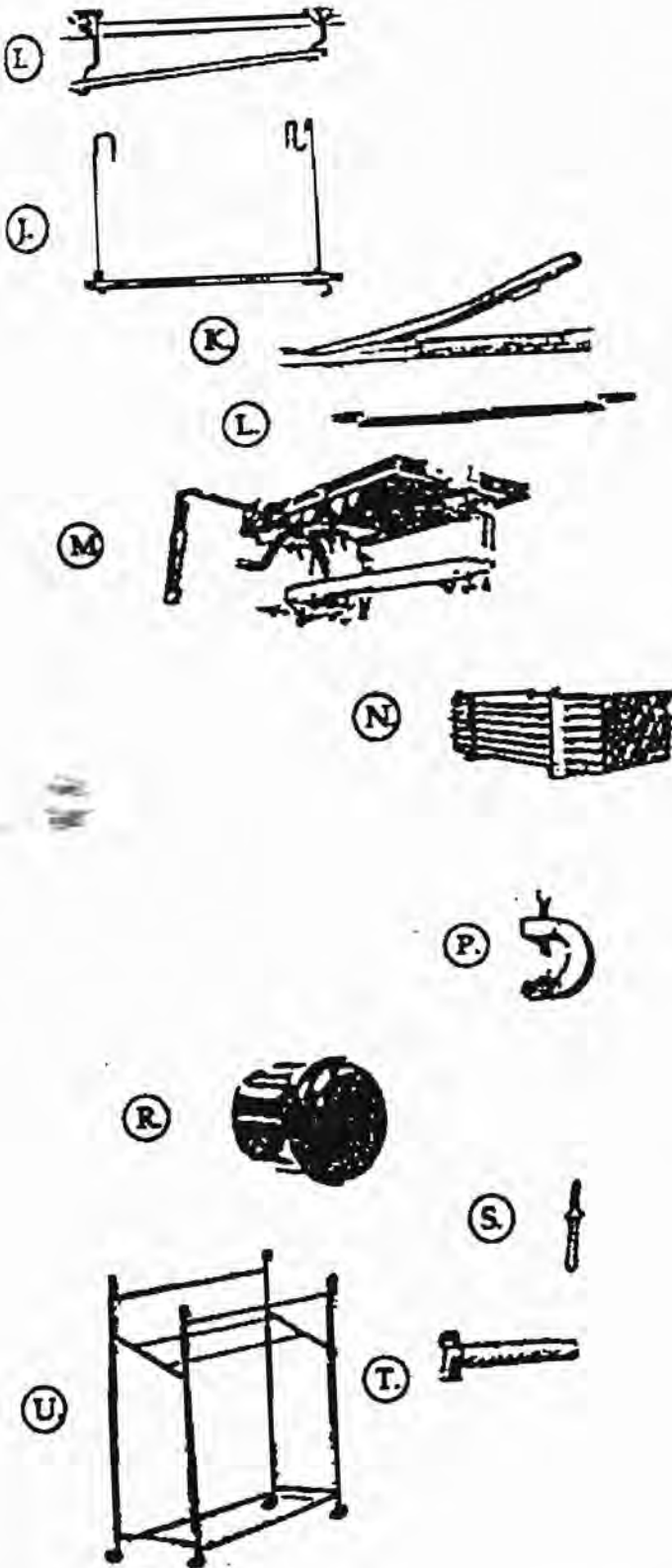

- I GARMENT CARRIERS
(sizes 30", 36", 42", other sizes available)
Anti Slide Pins (each)
- J FOLDING CARRIER EXTENSION 32" Long
36", 42"
- K SWITCHES 45° OR STRAIGHT
1-5/16" Manual or Automatic
- L REMOVABLE BAR SET
1-5/16"
Knuckles only
- M MASTERSWITCHES- 1-5/16"
Specify left or right
Inside or outside
- N HIGH FINISH ZINC PLATED 14 GA. TUBING
Lengths: 10', 10 1/2', 12', 21'
3/4" - 1029 O.D. per ft.
1-1/4" - 1250 O.D. per ft.
1" - 1315 O.D. per ft.
1-5/8" - 1660 O.D. per ft.
- O SUSPENSION C CLAMPS
Suspension Cups
Suspension Clamps, 2 pc.
- P RUBBER END CAPS
3/4"
1"
- Q PINS (per 100)
1-1/4" anchor 1 piece nail drive
- R SELF DRILLING and TAPPING SCREWS
3/4"-10/32 Hex Slotted (per 1000)
1"-10/32 Hex Slotted (per 1000)
- S TROLLY TRANSFER RACK
- T SLEEVES 1-5/16"
Sleeves 1-1/16"

Tel: (212) 279-3878

TED STEEL INDUSTRIES LTD
SPEED RAIL AND GARMENT RACKS
STEEL PARTITION AND SHELVING

361 W. 36th Street
New York, NY 10018

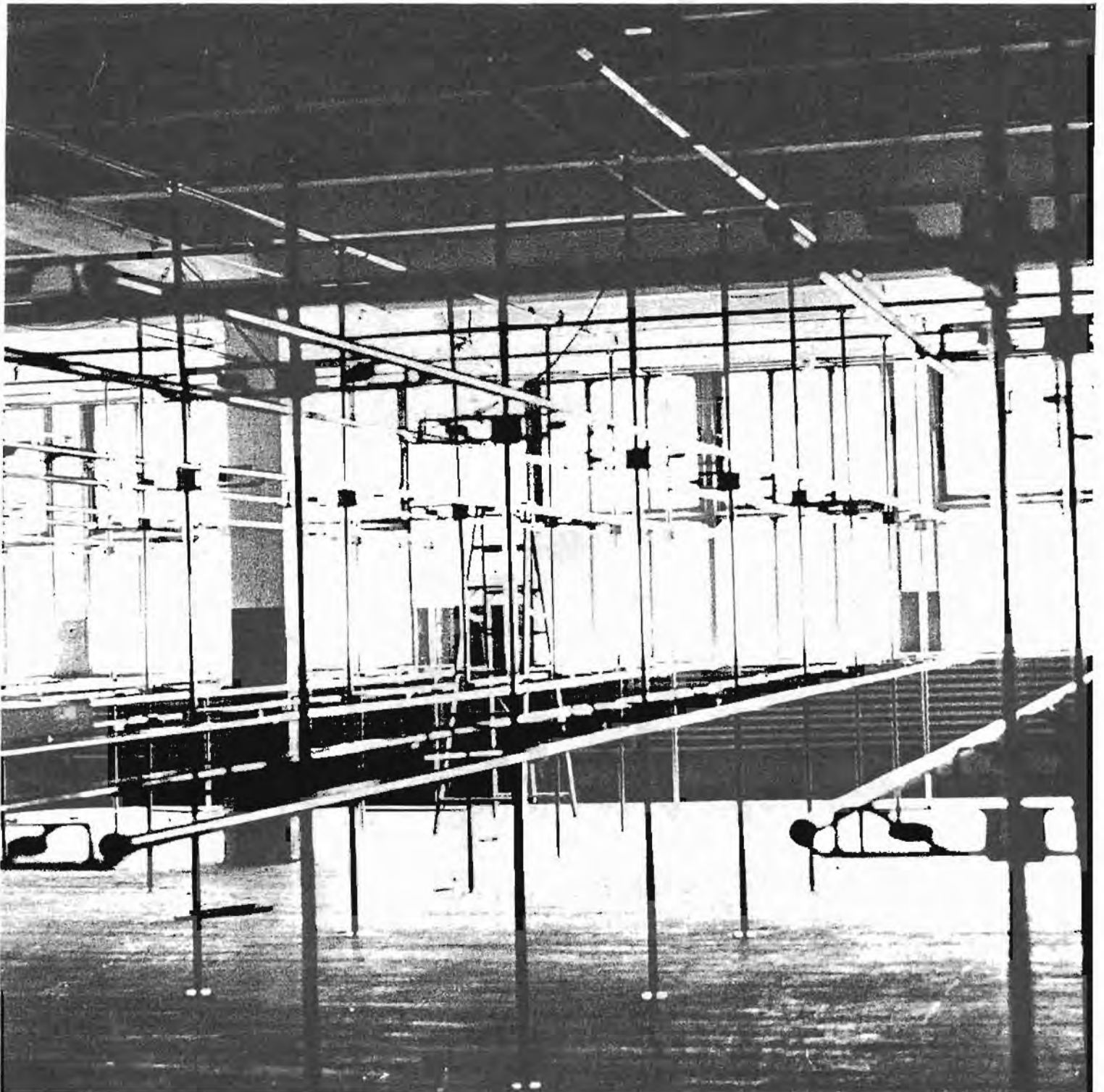

Tel: (212) 279-3878

TED STEEL INDUSTRIES LTD
SPEED RAIL AND GARMENT RACKS
STEEL PARTITION AND SHELVING

361 W. 36th Street
New York, NY 10018

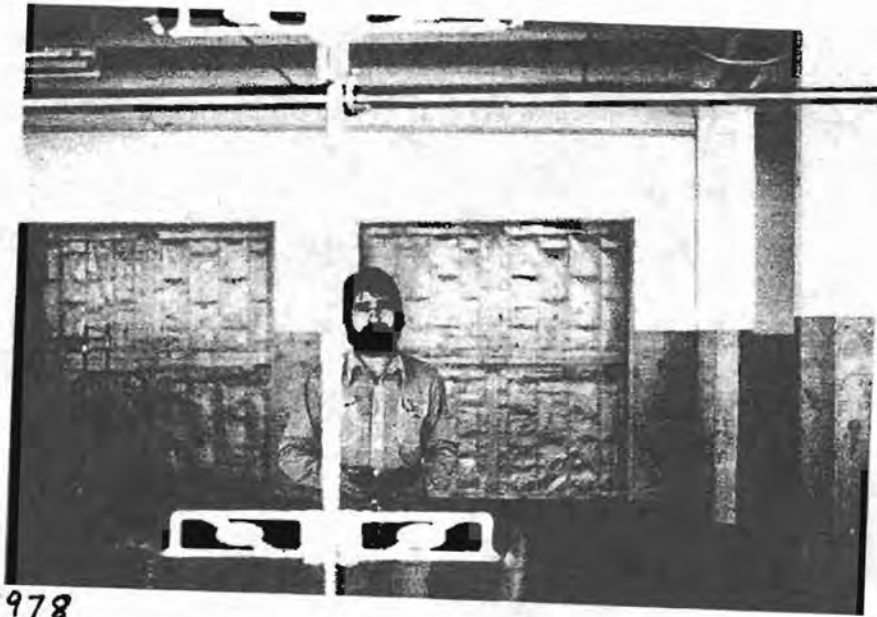

1978

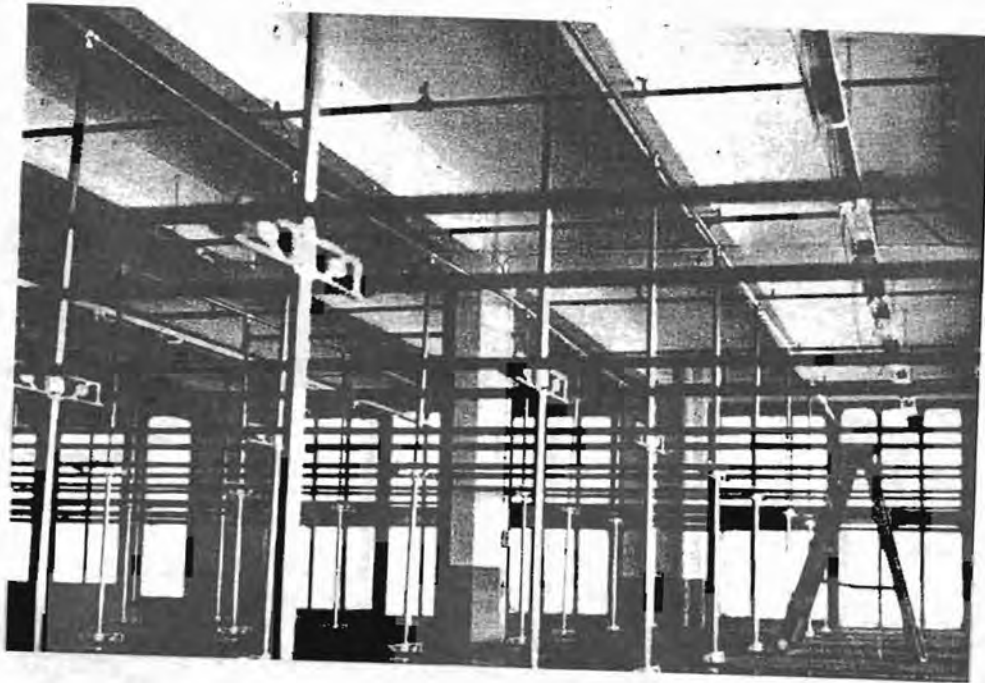

POST

3'3"
 4'3"
 5'3"
 6'3"
 7'3"
 8'3"
 9'3"
 10'3"
 11'3"
 12'3"
 13'3"
 14'3"

RE BARS

24"
 30"
 36"
 42"
 48"

PERF. FLATS

3'3"
 4'3"

SHELVES

12x24
 12x30
 12x36
 12x42
 12x48
 15x24
 15x30
 15x36
 15x42
 15x48
 18x24
 18x30
 18x36
 18x42
 18x48
 24x24
 24x30
 24x36
 24x42
 24x48
 30x30
 30x36
 30x42

30x48
 36x36
 36x42
 36x48
 42x42
 42x48

PREF SHELVES

EXTRA***

SWAY BRACES

9"
 12"
 15"
 18"
 21"
 24"
 30"
 36"
 42"
 48"

BOLTS per 100

5/8"
 1"

LABEL HOLDER

30"
 36"
 42"
 48"

BACK & SIDES

12x3'3"

12x4'3"

12x5'3"

12x6'3"

12x7'3"

12x8'3"

12x9'3"

12x10'3"

18x3'3"

18x4'3"

18x5'3"

18x6'3"

18x7'3"

18x8'3"

18x9'3"

18x10'3"

24x3'3"

24x4'3"

24x5'3"

24x6'3"

24x7'3"

24x8'3"

24x9'3"

24x10'3"

36x3'3"

36x4'3"

36x5'3"

36x6'3"

36x7'3"

36x8'3"

36x9'3"

36x10'3"

42x3'3"

42x4'3"

42x5'3"

42x6'3"

42x7'3"

42x8'3"

42x9'3"

42x10'3"

5

48x3'3"

48x4'3"

48x5'3"

48x6'3"

48x7'3"

48x8'3"

48x9'3"

48x10'3"

SPECIAL

Sizes add

BASES & BIN FRONTS

2x15

2x18

2x24

2x30

2x36

2x42

2x48

DIVIDERS

6x12

6x15

6x18

8x12

8x15

8x18

10x12

10x15

10x18

12x12

12x15

12x18

14x12

14x15

14x18

16x12

16x15

16x18

ALL RACKS INDUSTRIES, INC.

SPEED RAIL AND GARMENT RACKS
STEEL PARTITION AND SHELVING

325 WEST 38TH STREET
NEW YORK, N. Y. 10018



**STANDARD
ENCLOSED UNIT**



SKELETON



**STANDARD UNIT WITH
BACK and SIDE**



**PART BIN WITH
BIN FRONTS**



PART BIN

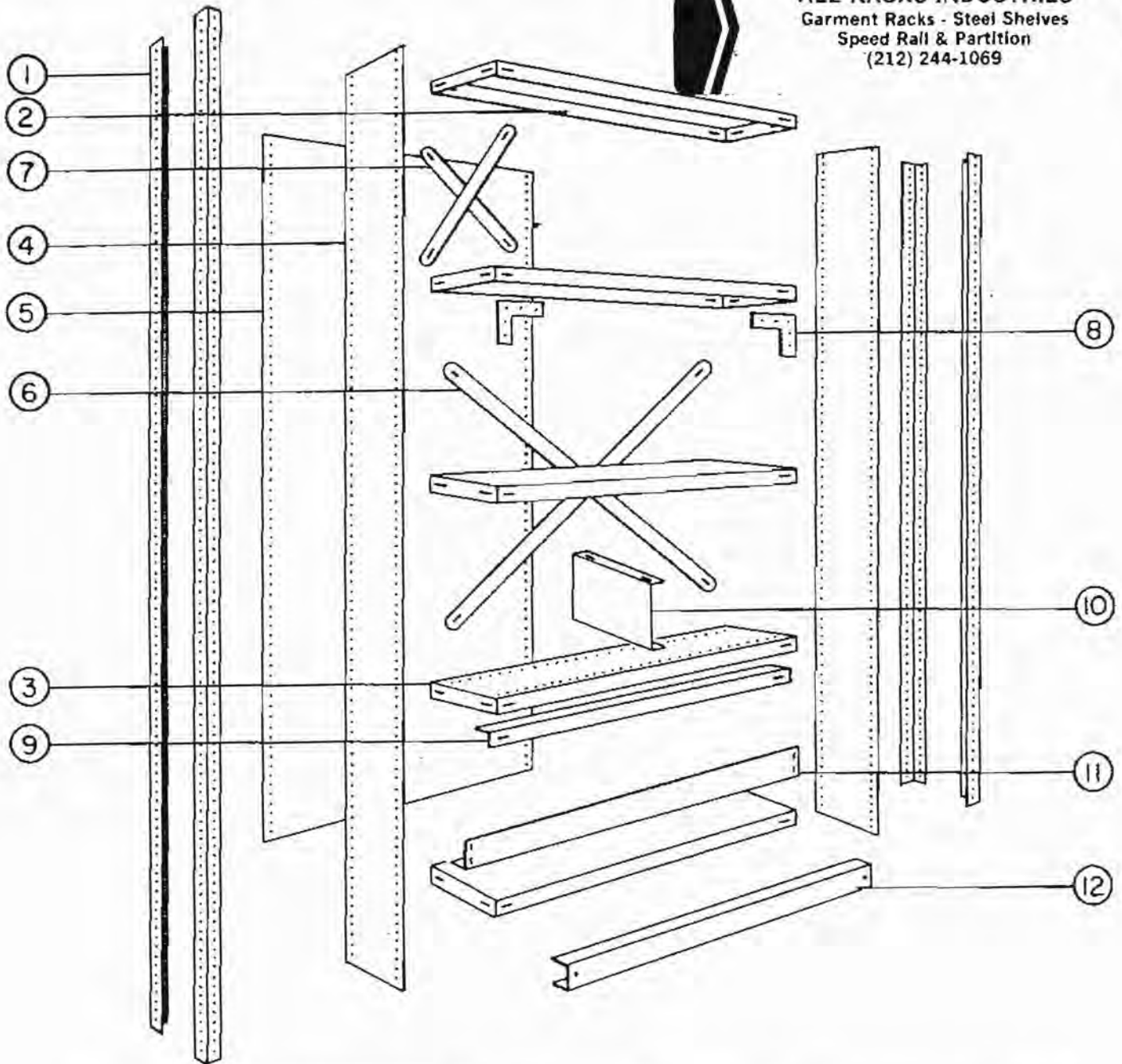

- | | | |
|--|---|--|
| <p>1. POST:
 Roll formed 12 gauge rail steel angle upright $1\frac{1}{4} \times 1\frac{1}{4}$ with holes punched on both legs 1" on center for vertical adjustment of shelves. Lengths of 3'3", 4'3", 4'3", 5'3", 6'3", 7'3", 8'3", 9'3", 10'3", 11'3", 12'3".</p> <p>2. SHELF:
 Formed into channel shape with vertical and two return flanges on all four sides (triple Bend) for added strength. Stock sizes are 24", 30", 36", 42", 48" wide, depths of 9", 12", 15", 18", 24", 30", 36". Special sizes are also available.</p> <p>3. PERFORATED SHELF:
 Shelves are punched on 1" centers to accommodate shelf dividers. Stock sizes are the same as above.</p> | <p>4. SIDE PANEL:
 Used on closed type shelving. One panel may be common to two adjacent units. (Sides over 4'3" consist of overlapping pieces.)</p> <p>5. BACK PANEL:
 Used on closed type shelving. One panel may be common to back to back units. (Backs over 4'3" consist of overlapping pieces.)</p> <p>6. BACK SWAY BRACE:
 Used on open type shelving to prevent lateral sway and add rigidity.</p> <p>7. SIDE SWAY BRACE:
 Used on open type shelving for added rigidity.</p> <p>8. ANGLE SWAY:
 Used in place of sway braces when unobstructed entry is required.</p> | <p>9. REINFORCEMENT ANGLE:
 12 Gauge Rail Steel angle snaps into flange of shelf. Used to prevent deflection of heavily loaded shelf.</p> <p>10. SHELF DIVIDER:
 Used to divide shelf into bin compartments. Attaches to shelves with clips or nuts and bolts.</p> <p>11. BIN FRONT:
 Prevents small items from rolling out of bins. Attaches to upright post.</p> <p>12. BASE STRIP:
 Prevents litter from accumulating under shelf, adds strength to bottom shelf.</p> <p>FINISH:
 Durable baked-on gray enamel. Other colors available on request.</p> |
|--|---|--|

Terms: Net
FOB Warehouse

Monorail Racking Systems

Prices Subject to Change
Without Prior Notice

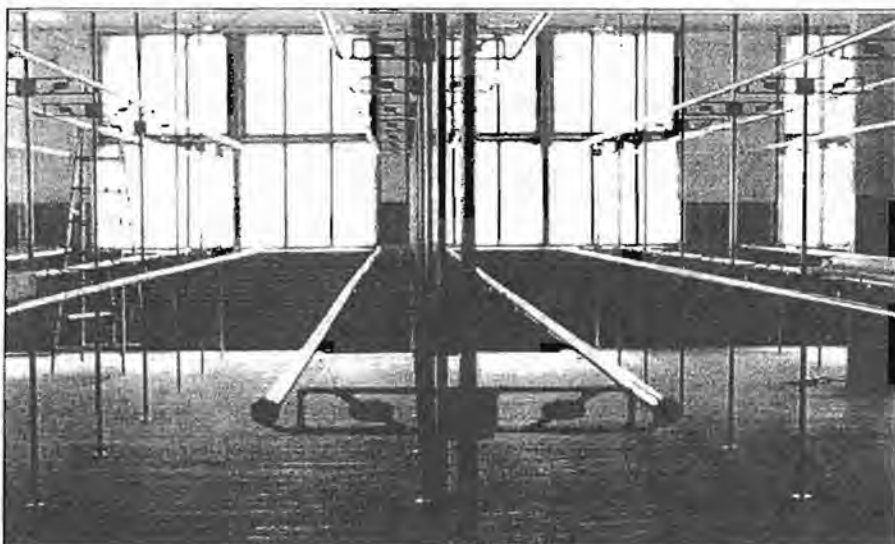

Ideal for Maximizing Storage Capacity in
Warehouse/Factory Store/ Storeroom/Showroom in
Galvanized or Chrome Tubing

The New Industrial Hi-Tech Look

Expert Installation from Small Spaces in Stores
and Showrooms to Large Warehouse
and Factory Systems

CALL FOR AN APPOINTMENT OR FAX US YOUR
LAYOUT. WE WILL PROVIDE A FREE ESTIMATE.

NO JOB TOO
BIG
OR TOO
SMALL

For Store and
Showroom Connectors
see Page 10.
For Chrome Plated
Tubing see Page 23.

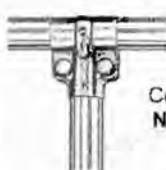

3-Way Connector
Connects 1" to 1" Tubing
No. ZC311 ea.
Connects 1 1/4" to 1 1/4" Tubing
No. ZC3125125 ea.
Connects One 1 1/4" Tube
to 1" Tubing
No. ZC31251 ea.
Connects One 1" Tube
to 1 1/4" Tubing
No. ZC31125 ea.



Flange
For Threaded 1 1/4" Tubing
No. FL125 ea.
For Threaded 1" Tubing
No. FL1 ea.

Zinc Plated Pipe Connectors

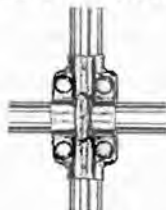

4-Way Connector
Connects 1" to 1" Tubing
No. ZC411 ea.
Connects 1 1/4" to 1 1/4" Tubing
No. ZC4125125 ea.
Connects 1 1/4" Tubing to 1" Tubing
No. ZC41251 ea.

Galvanized Tubing
1" Outside Diam.
No. GL-100
1 1/4" Outside Diam.
No. GL-AH746
See Page 23 for Prices.



Floor or
Ceiling Jack
with Flange
For 1 1/4" Tubing
No. ZCFL
ea.

**Cross-Brace
4-Way
Pipe Connector**
Connects two pipes
without making it
necessary to
cut either one of them.
Connects 1" to 1" Tubing
No. ZCB411 ea.
Connects 1 1/4" to 1 1/4"
Tubing
No. ZCB4125125
ea.
Connects 1 1/4"
to 1" Tubing
No. ZCB41251
ea.



Industrial Shelving

Made of Steel In Grey Baked Enamel
Shelves - 20 gauge
Posts and Braces - 12 gauge



Open
Starter Unit

Available in a wide variety of widths, depths and heights. All units are re-usable - they are put together with Nuts and Bolts, and can be reconfigured to meet your changing requirements. Units shown here are just a few of the multitude of configurations with heights ranging from 3 feet to 14 feet. Call for more information and a **FREE ON-SITE Estimate**, to include delivery and installation.

5 SHELF UNIT
No. TS-2436/5
ea.

6 SHELF UNIT
No. TS-2436/6
ea.

7 SHELF UNIT
No. TS-2436/7
ea.

Additional shelves can
be added as needed.

PIECE GOODS

Industrial Units
(Not Shown)
30" D x 42" W x 99" H

2 units go back-to-back to
accommodate 60" rolls of
fabric.

Prices include 12-gauge
reinforcement bar for
extra support

STARTER UNIT

Includes:
• Sway Brace
• 5 Shelf Starter Unit
comprised of 2
back-to-back single
units

Each shelf is 24" apart
and includes front and
back reinforcements.

No. TS-3042/S
per unit

ADD-ON UNIT

No. TS-3042/Add
per unit

OPEN UNITS

prices include Back and
Side Braces
24" D x 36" W x 87" H

CLOSED UNITS

closed back and sides
These units are available
in sizes ranging from
12" x 24" to 42" x 48"

Closed
Starter Unit



Closed
Add-On Unit



CLOSED UNITS

5-Shelf Starter Unit
24" x 36" x 87" H
No. TS-24365/CL
ea.

5 Shelf Add-On Unit
No. TS-24365/A
ea.

NOTE: Prices do not include delivery or installation.